

ED. 11/2011

PART CATALOGUE
STD-306
TIRE CHANGER

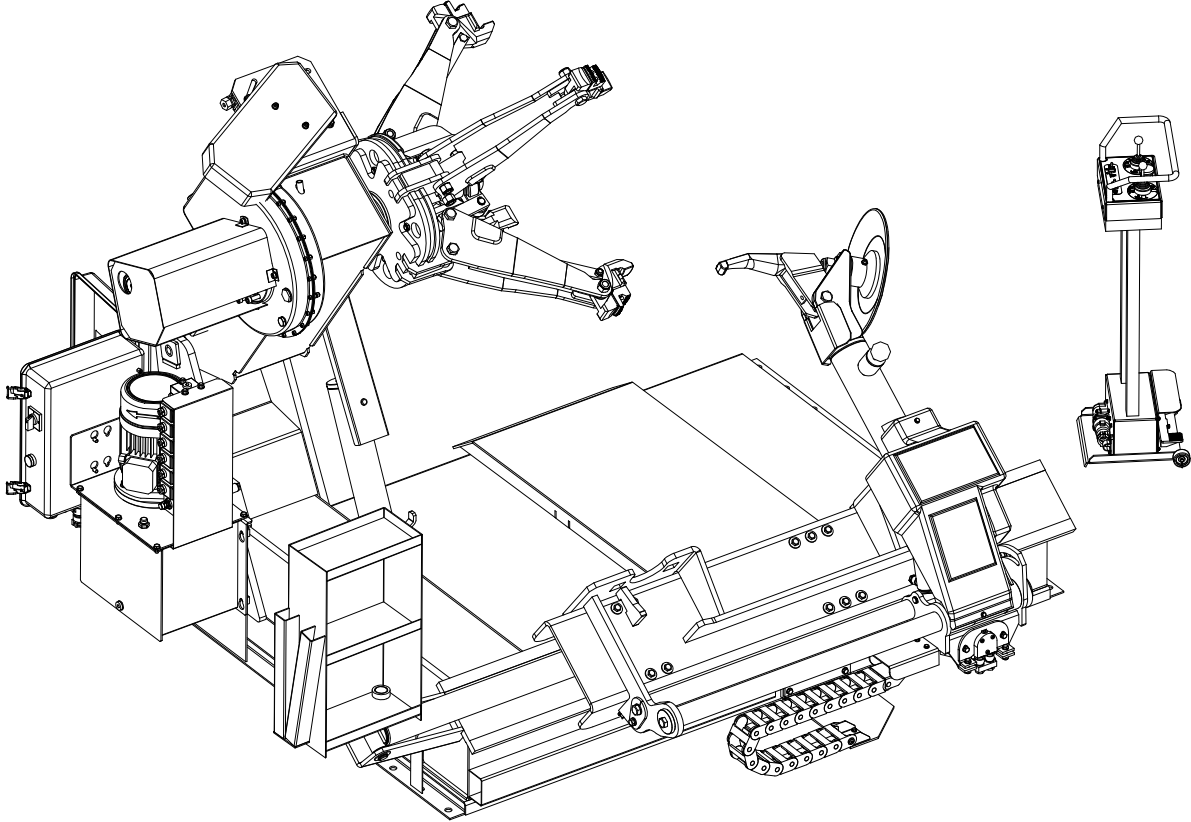

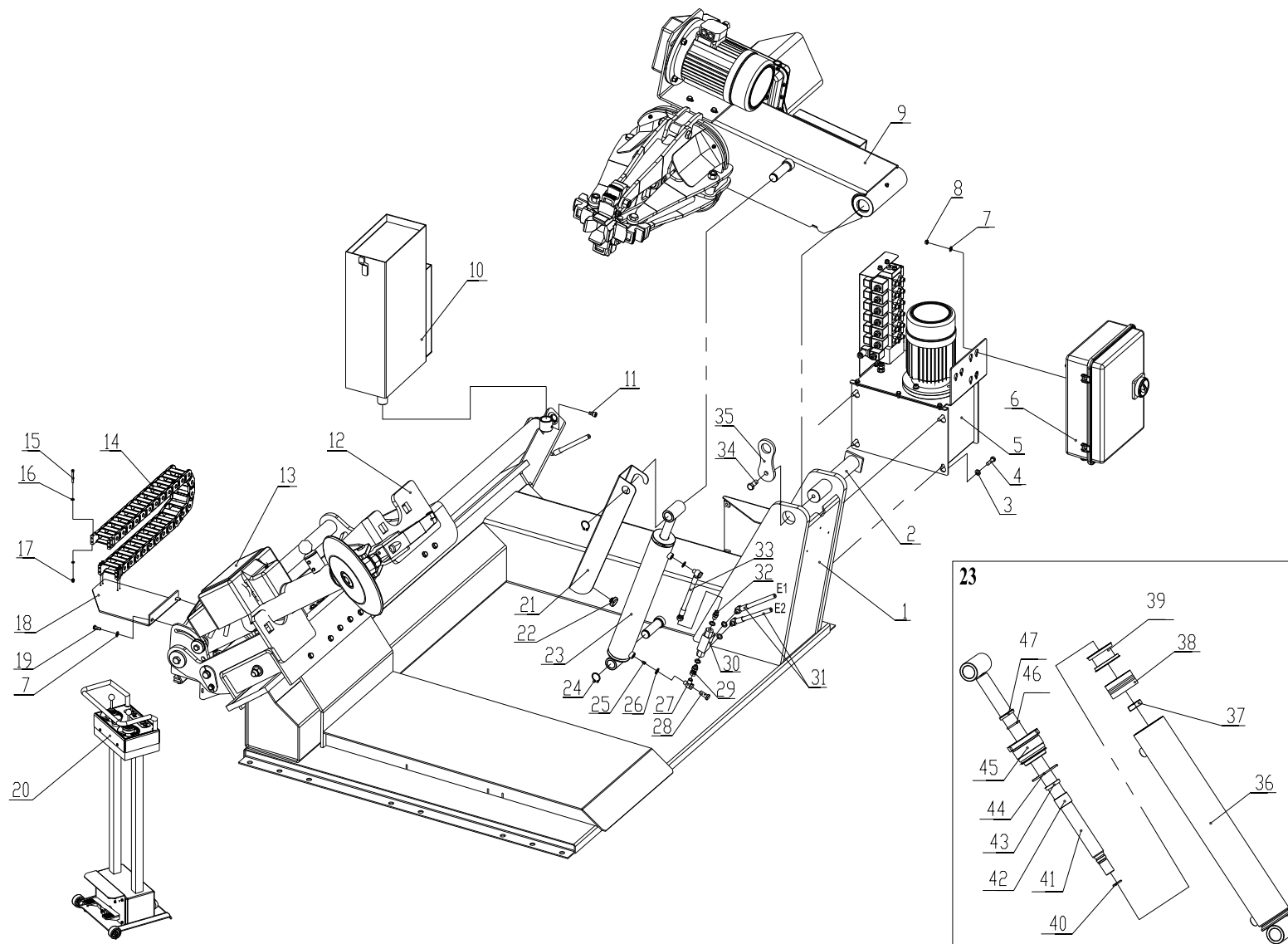

TAV.0	GENERAL BREAKDOWN	ED. 11/11
-------	-------------------	-----------

ITEM	PART NO.	DESCRIPTION	QTY	REMARK
1	C56B110000	Frame	1	
2	C56B010000	Arm pin	1	
3	0205011	Washer D.10	9	
4	0201050	Screw M10X35	4	
5	C56BY10000	Hydraulic power unit	1	
6	C56BD11000	Electric unit	1	
7	0205008	Washer D.8	5	
8	0203029	Nut M8	3	
9	C56B200000B	Self-centering chuck	1	
10	C56B600000	Tool shelf	1	
11	0202056	Screw M10X16	1	
12	C56B300000	Tool arm saddle	1	
13	C56B400000	Tool holder arm	1	
14	0511025	Chain 25X75X28	1	
15	0202023	Screw M5X45	8	
16	GB/T97.1	Washer D.5	8	
17	0204002	Self-locking nut M5	4	
18	C56B100001	Chain support	1	
19	0201042	Screw M8X20	2	
20	C56BD12000	Mobile control unit	1	
21	C56B000001	Cylinder guard	1	
22	C56B000002	Shock absorber	1	
23	C56BY20000	Chuck arm cylinder	1	
24	0212021	Seeger D.30	2	
25	BZ-GZ-002	Special screw M8X12	1	
26	0313001	Washer 1/4	6	
27	0304010	Rotation union 1/4	1	

28	BZ-720B-0401	Special screw	1
29	0305002	Union 1/4	1
30	0307042	Stop valve	1
31	C56BWJ1300	Hydraulic hose L=1300	2
32	0302007	Union 1/4	1
33	C56BZJ300X	Hydraulic hose L=300	1
34	0201092	Screw M14X30	1
35	C56B010002	Hoisting hook	1
36	C56BY22000	Cylinder liner	1
37	0203026	Nut M22X1.5	1
38	0312014	Gasket 70X50	1
39	YA-70-3	Piston	1
40	0309022	O-ring 24X2.4	1
41	C56BY24000	Cylinder shaft	1
42	0305006	Guiding ring 30X25X2.5	1
43	0310009	Sealing ring 30X38X7	1
44	0309050	O-ring 70X3.1	1
45	C56BY28005	Cylinder guiding cover	1
46	0309027	O-ring 35X3.1	1
47	0311005	Scraper D.30	1

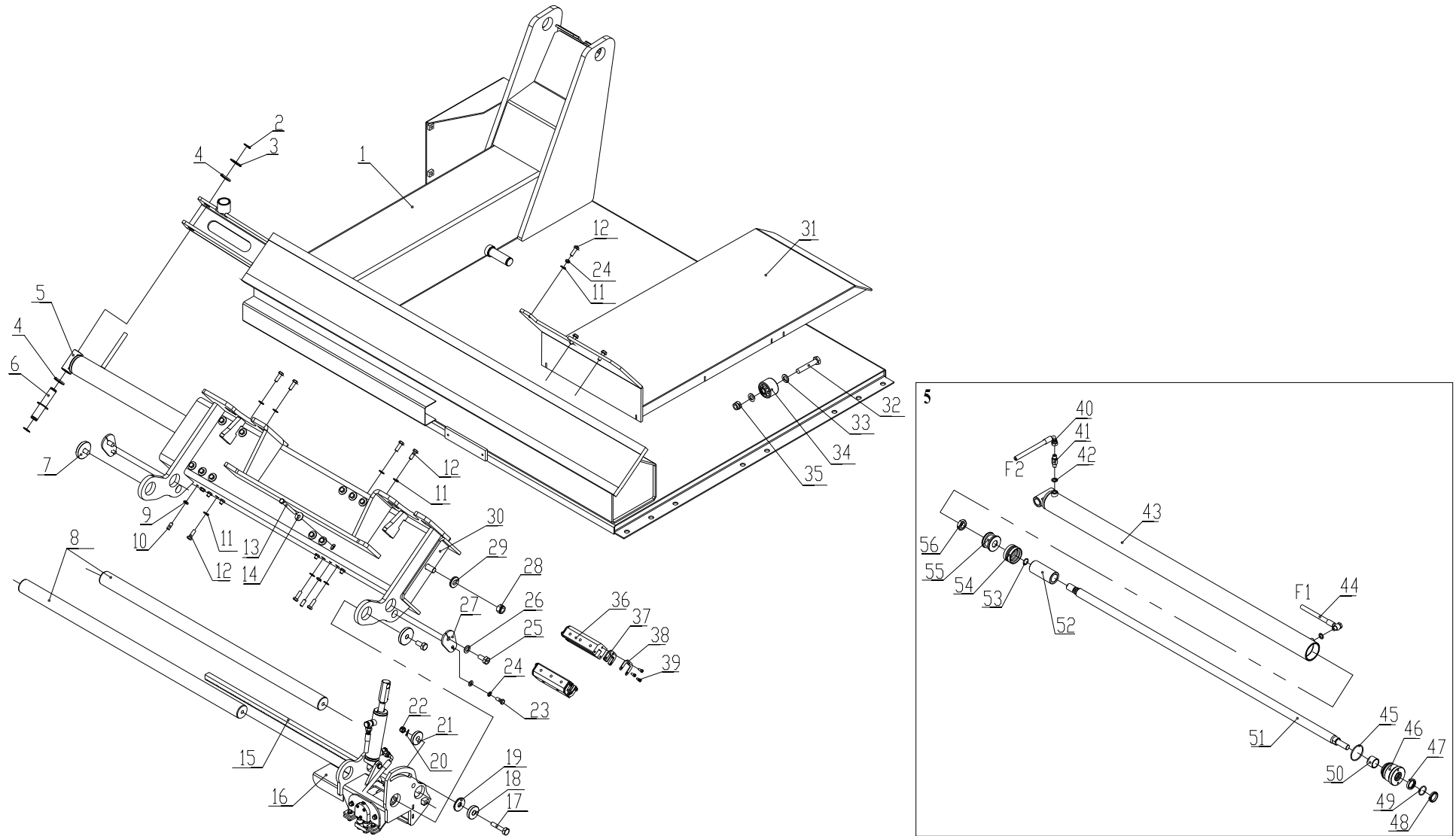

TAV.1.0	FRAME	ED. 11/11
---------	-------	-----------

ITEM	PART NO.	DESCRIPTION	QTY	REMARK
1	C56B11000	Frame	1	
2	0212003	Seeger D.24	2	
3	YC8-4399289	Washer	2	
4	C56B000003	Washer	2	
5	C56BY30000	Carriage cylinder	1	
6	C56B000004	Pin	1	
7	YC8-3001067	Washer	2	
8	C56B300001	Shaft	2	
9	0204012	Nut M10	6	
10	0209024	Screw M10X25	6	
11	0205011	Washer D.10	11	
12	0201049	Screw M10X30	11	
13	0201141	Screw M10X100	12	
14	0205010	Washer D.10	12	
15	C56B320001	Rack	1	
16	C56B320000	Tool arm saddle	1	
17	0201081	Screw M12X60	1	
18	C56B320005	Washer	1	
19	C56B320006	Nylon washer	1	
20	0205013	Washer D.12	1	
21	C56B320007	Nylon washer	1	
22	0204007	Self-locking nut M12	1	
23	0201065	Screw M10X20	2	
24	0208007	Spring washer D.10	5	
25	0201092	Screw M14X30	4	
26	0205017	Washer D.14	2	
27	C56B300002	Fastening plate	2	

TAV.1.0	FRAME	ED. 11/11
---------	-------	-----------

28	0204009	Self-locking nut M18	1
29	C56B000005	Washer	1
30	C56B311000	Carriage	1
31	C56B510000	Ramp	1
32	0201099	Screw M16X90	3
33	0205020	Washer D.16	6
34	YC8-4299251	Roller	3
35	0204008	Self-locking nut M16	3
36	YC8-3000980A	Carriage slide	2
37	YC8-4299307	Scraper	4
38	YC8-3001062	Side plate	8
39	0202024	Screw M6X12	24
40	C56BWW2200	Hydraulic hose L=2200	1
41	0302004	Union 1/4	1
42	0313001	Washer 1/4	2
43	C56BY32000	Cylinder liner	1
44	C56BWJ3230	Hydraulic hose L=3230	1
45	0309032	O-ring 60X3.1	1
46	YC8-60-5	Cylinder guiding cover	1
47	0310009	Sealing ring 30X38X7	1
48	0311005	Scraper D.30	1
49	0309027	O-ring 35X3.1	1
50	0305006	Guide ring 30X25X2.5	1
51	C56BY34001	Cylinder shaft	1
52	C56BY38006	Spacer	1
53	0309022	O-ring 24X2.4	1
54	0312002	Gasket 60X44	1

TAV.1.0	FRAME	ED. 11/11
---------	-------	-----------

55	YC8-60-3	Piston	1
56	0203026	Nut M22X1.5	1

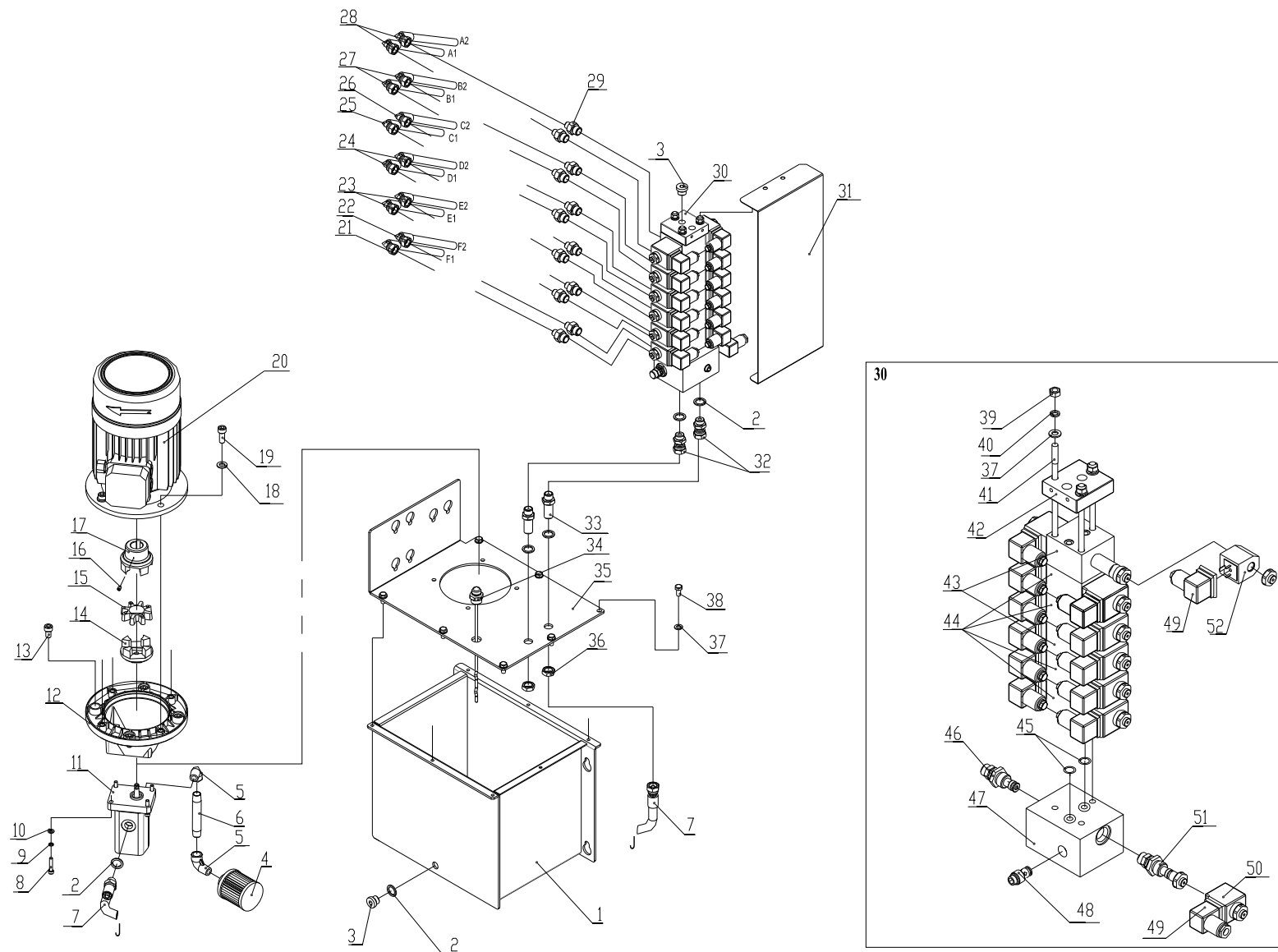

TAV.5.0	HYDRAULIC POWER UNIT	ED. 11/11
---------	----------------------	-----------

ITEM	PART NO.	DESCRIPTION	QTY	REMARK
1	C56BY11000	Oil tank	1	
2	0313012	Washer 3/8	6	
3	0305018	Plug 3/8	2	
4	0305011	Oil filter 3/8X72	1	
5	0303007	90° union 3/8	2	
6	BZ-G18X100	Oil draining pipe	1	
7	303-ZY5/16-390	Hydraulic hose L=390	1	
8	0202026	Screw M6X30	4	
9	0208005	Spring washer D.6	4	
10	0205006	Washer D.6	4	
11	0301029	Gear pump 8.0CC	1	
12	YC8-4197872	Motor flange	1	
13	0202056	Screw M10X16	4	
14	YC8-4197873C	Pump joint	1	
15	YC8-4197873A	Rubber absorber	1	
16	0209009	Screw M6X8	1	
17	YC8-4197873B	Motor joint	1	
18	0205011	Washer D.10	4	
19	0202061	Screw M10X25	4	
20	0509124	Motor 400V/3PH 2.2KW	1	
21	C56BWJ3230	Hydraulic hose L=3230	1	
22	C56BWW2200	Hydraulic hose L=2200	1	
23	C56BWJ1300	Hydraulic hose L=1300	2	
24	C56BWJ1750	Hydraulic hose L=1750	2	
25	C56BWW5000	Hydraulic hose L=5000	1	
26	C56BZ5150	Hydraulic hose L=5150	1	
27	C56BZW5330	Hydraulic hose L=5330	2	

TAV.5.0	HYDRAULIC POWER UNIT	ED. 11/11
---------	----------------------	-----------

28	C56BBZW5000	Hydraulic hose L=5000	2
29	0305043	Union	12
30	0307055	Multiple base with solenoid valves	1
31	C56BY18002	Protection	1
32	0305003	Union 3/8	2
33	0305004	Union 3/8	2
34	YC8-3010652	Oil level plug	1
35	C56BY18001	Tank cover plate	1
36	0305045	Locking nut	2
37	0205008	Washer D.8	10
38	0201026	Screw M8X16	7
39	0203029	Nut M8	3
40	0208006	Spring washer D.8	3
41	GB/T899	Screw M8X320	3
42	TC0000	Closing plate	1
43	C161403002	ED08Z modular directional valve 24VDC	2
44	C161401002	ED06Z modular directional valve 24VDC	4
45	C000110000	O-ring 8.73X1.78	2
46	041149035620810	VSBN-08A-20-81 relief valve 105-210bar	1
47	B2210S2809	Interface block	1
48	V389209000	VU3/8 check valve 0.6bar	1
49	0307026	Connector	13
50	0307059	S-CE coil 24VDC18W	1
51	0307098	2/2 electric valve normally open VE3-NA	1
52	0307099	S-CE coil 24VDC ED06Z/ED08Z	12

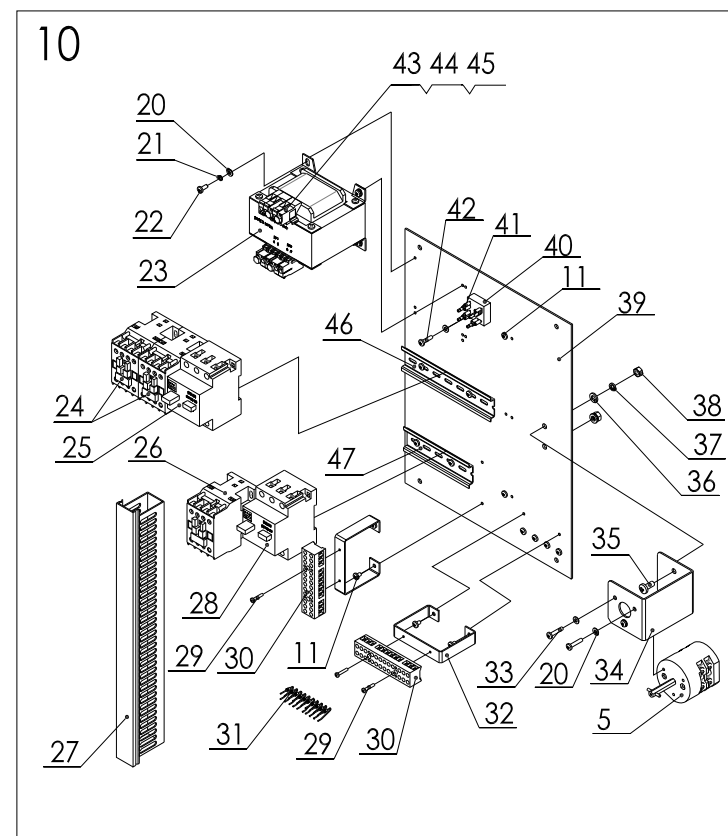
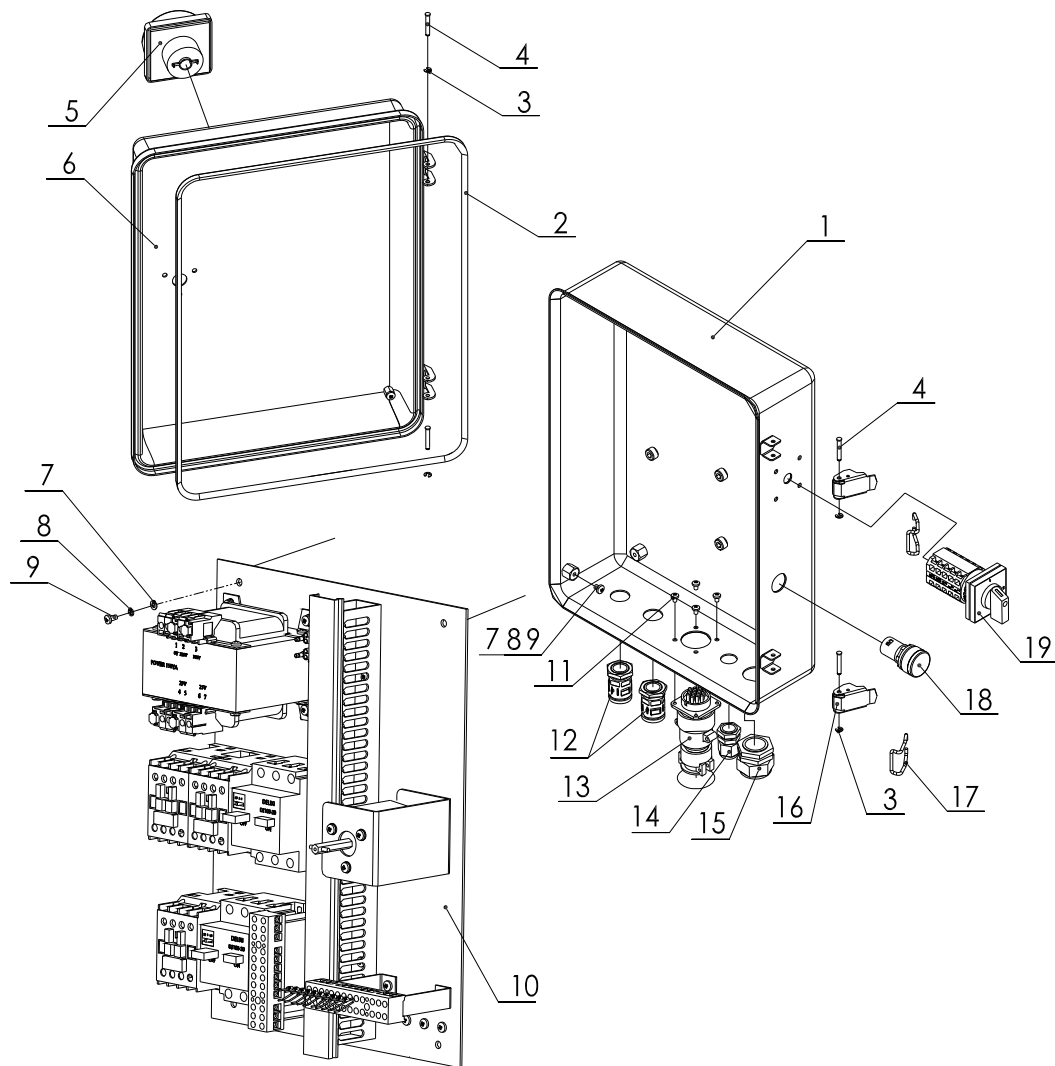

TAV.6.0	ELECTRIC UNIT	ED. 11/11
---------	---------------	-----------

ITEM	PART NO.	DESCRIPTION	QTY	REMARK
1	S551-01D	Back cover	1	
2	S551-02-5	Gasket	1	
3	GB/T896	Seeger D.3.5	4	
4	S551-6	Pin	4	
5	0505025	Power switch 20A	1	
6	S551-02	Front cover	1	
7	0205004	Washer D.5	6	
8	0208003	Spring washer D.5	6	
9	0206024	Screw M5X10	6	
10	C56BD11100	Electric component unit	1	
11	0206019	Screw M4X6	18	
12	454132700	Ferrule M20 - D18.5	2	
13	0507165	Cable connector P32-19	1	
14	0507044	Cable holder M20	1	
15	0508012	Cable holder M27	1	
16	S551-5	Clamp	2	
17	S551-4	Hook	2	
18	0502023	Pilot lamp AC24V	1	
19	0505013	Pole change switch 20A	1	
20	0205002	Washer D.4	12	
21	0208002	Spring washer D.4	4	
22	0206012	Screw M4X10	4	
23	0503002	Transformer 230/400V /29V-25V	1	
24	0501004	Contactor 1801 AC24V	2	
25	0501007	Breaker 4-6.3A	1	
26	0501002	Contactor 1210 AC24V	1	
27	454134800	Wiring terminal 30X50X370	1	

TAV.6.0	ELECTRIC UNIT	ED. 11/11
---------	---------------	-----------

28	0501020	Breaker 6.3-10A	1
29	GB/T818	Screw M3X16	4
30	0507009	Terminal board H3081-12	2
31	0507027	LED - IN5408	10
32	CC-850223	Support	2
33	0206016	Screw M4X20	3
34	CC-850222	Switch support	1
35	0206040	Screw M6X12	2
36	0205006	Washer D.6	2
37	0205006	Spring washer D.6	2
38	0203029	Nut M6	2
39	3054510400	Support plate	1
40	0508006	Rectifier - 3510	1
41	0507020	Reed 6.3	4
42	0206015	Screw M4X16	1
43	0504005	Overload cutoff 5A/5X20	1
44	0504003	Overload cutoff 2A/5X20	1
45	0504016	Overload cutoff 1A/5X20	1
46	454131808	Guide 35X150	1
47	454130900	Guide 35X110	1

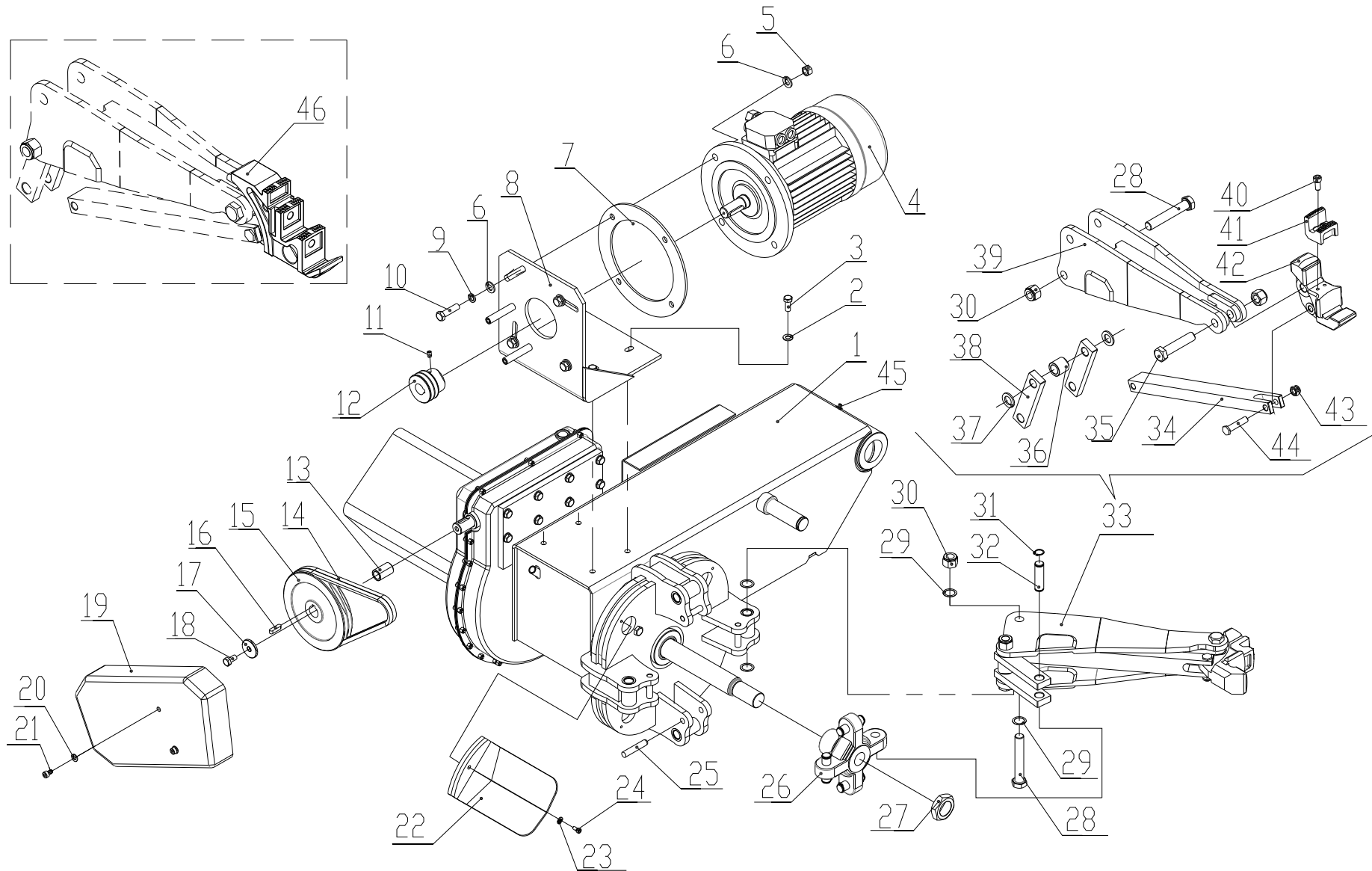

TAV.9.0

SELF-CENTERING CHUCK

ED. 11/11

ITEM	PART NO.	DESCRIPTION	QTY	REMARK
1	C56B200000A	Chuck arm	1	
2	0205011	Washer D.10	4	
3	0201064	Screw M10X25	4	
4	0509123	Double speed motor 400V/3PH 2.6KW/3.2KW	1	
5	0203023	Nut M12	4	
6	0205013	Washer D.12	8	
7	C56B240001	Spacer	1	
8	C56B241000	Motor support	1	
9	0208009	Spring washer D.12	4	
10	0201157	Screw M12X25	4	
11	0209032	Screw M8X12	1	
12	YC8-3000975	Motor pulley	1	
13	YC8-3000999a	Spacer	1	
14	0511077	Driven belt V 800	2	
15	YC8-3001052b	Driven pulley	1	
16	0213025	Tab 8X30	1	
17	YC8-3001068	Washer	1	
18	0201062	Screw M10X20	1	
19	C56B250000	Belt casing	1	
20	0205008	Washer D.8	2	
21	0202043	Screw M8X12	2	
22	C56B200002	ABS cover	4	
23	0205006	Washer D.6	4	
24	0202024	Screw M6X12	4	
25	0213039	Elastic pin 12X60	4	
26	YC8-3001050a	Turntable cross	1	
27	0204019	Nut M33X2	1	

TAV.9.0	SELF-CENTERING CHUCK	ED. 11/11
---------	----------------------	-----------

28	0201105	Screw M18X100X1.5	8	
29	YC8-4399974	Copper washer	16	
30	0204010	Self-locking nut M18X1.5	12	
31	0212016	Spring washer D.18	8	
32	YC8-3000993	Pin	4	
33	C56B230000	Clamp unit	4	
34	YC8-3000992	Bar	4	
35	0201107	Screw M18X85X1.5	4	
36	YC8-3000994	Spacer	4	
37	0205021	Washer D.18	8	
38	YC8-3001044a	Connection rod	8	
39	C56B231000	Arm	4	
40	0202060	Screw M10X20	8	
41	CC-510101	Clamp	4	
42	YC8-3000924	Clamp support	4	
43	0204007	Self-locking nut M12	4	
44	YC8-3000968	Special screw	4	
45	0215021	Greaser 8X1	1	
46	C56B230001	Special clamp	4	Optional

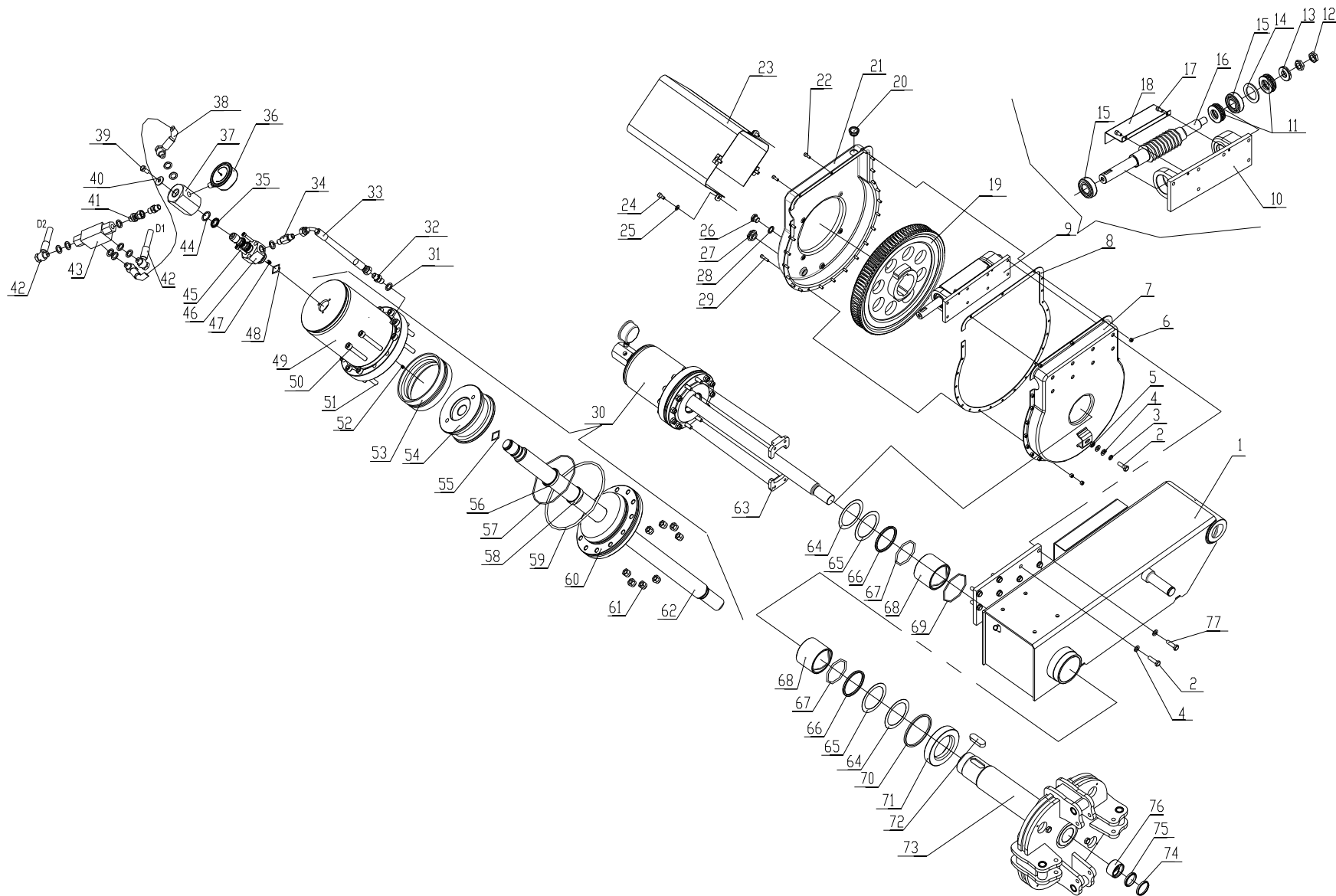

TAV.9.1

CHUCK ARM

ED. 11/11

ITEM	PART NO.	DESCRIPTION	QTY	REMARK
1	C56B210000	Chuck arm	1	
2	0201049	Screw M10X30	3	
3	0208007	Spring washer D.10	1	
4	0205011	Washer D.10	10	
5	0204012	Nut M10	1	
6	0203029	Nut M6	24	
7	YC8-2400995	Cover	1	
8	YC8-3001051	Gasket	1	
9	YC8-2004000	Worm unit	1	
10	YC8-3001009	Worm support	1	
11	0214009	Bearing 51205	2	
12	0204014	Nut M16X1.5	2	
13	YC8-3001114	Washer	1	
14	YC8-3001115	Spacer	1	
15	0214035	Bearing 6205	2	
16	YC8-3010861b	Worm screw	1	
17	0202024	Screw M6X12	2	
18	YC8-3001010	Oil screen	1	
19	YC8-3010838A	Helical gear	1	
20	YC8-4199258	Oil plug	1	
21	YC8-3000998	Cover	1	
22	0202032	Screw M6X16	22	
23	YC8-6609764	Pivot union cover	1	
24	0202040	Screw M8X16	4	
25	0205008	Washer D.8	4	
26	0305018	Oil plug 3/8	1	
27	0215024	Oil level indicator M27X1.5	1	

TAV.9.1	CHUCK ARM	ED. 11/11
---------	-----------	-----------

28	0313012	Washer 3/8	1
29	0202034	Screw M6X25	1
30	C56BY40000	Chuck cylinder unit	1
31	0313001	Washer 1/4	11
32	0302007	Union 1/4	3
33	303-ZW170	Hydraulic hose L=170	1
34	0302004	Union 1/4	2
35	C-2C120-85-7	Ring for sealing	3
36	0307052	Pressure gauge 250bar	1
37	YC8-140-2	Pivot union body	1
38	303-JJ430	Hydraulic hose L=430	2
39	0201026	Screw M8X16	1
40	0205009	Washer D.8	1
41	0305002	Union 1/4	1
42	C56BWJ1750	Hydraulic hose L=1750	2
43	0307020	Stop valve	1
44	0313014	Sealing ring 20X3.53	3
45	0202026	Screw M6X30	3
46	YC8-140-3	Pin	1
47	0305001	Plug QD07	1
48	0309025	O-ring 30X3.1	1
49	YC8-140-4	Cylinder liner	1
50	0202057	Screw M10X70	4
51	0202066	Screw M10X60	8
52	0209025	Screw M8X12	1
53	0312008	Gasket 140X115X25.4	1
54	YC8-140-5	Piston	1

TAV.9.1	CHUCK ARM	ED. 11/11
---------	-----------	-----------

55	0309025	O-ring 32X3.1	1
56	0310013	Sealing ring 40X50X6	1
57	0309046	O-ring 140X3.1	1
58	0305012	Guide ring 40X12X2.5	1
59	0309049	O-ring 195X5.7	1
60	YC8-140-7	Cylinder guide cover	1
61	0204005	Self -locking nut M10	8
62	C56BY44001	Cylinder shaft	1
63	YC8-3008803	Locking plate	2
64	YC8-3001056	Spacer	2
65	YC8-3001057	Self-lubricated washer	2
66	YC8-4299308	Steel ring	2
67	0606013	O-ring 90X5.3	2
68	YC8-3001041	Bush for chuck rod	2
69	GB3452.	O-ring 97.5X3.55	1
70	0511119	Felt 115X106X5	1
71	C56B200001	Ring for felt	1
72	0213029	Tab 20X60	2
73	C56B220000	Chuck turntable	1
74	YC8-4299309	Steel ring for scraper	1
75	0311008	Scraper D.40	1
76	YC8-3010893A	Bush for chuck rod	1
77	0201050	Screw M10X35	6

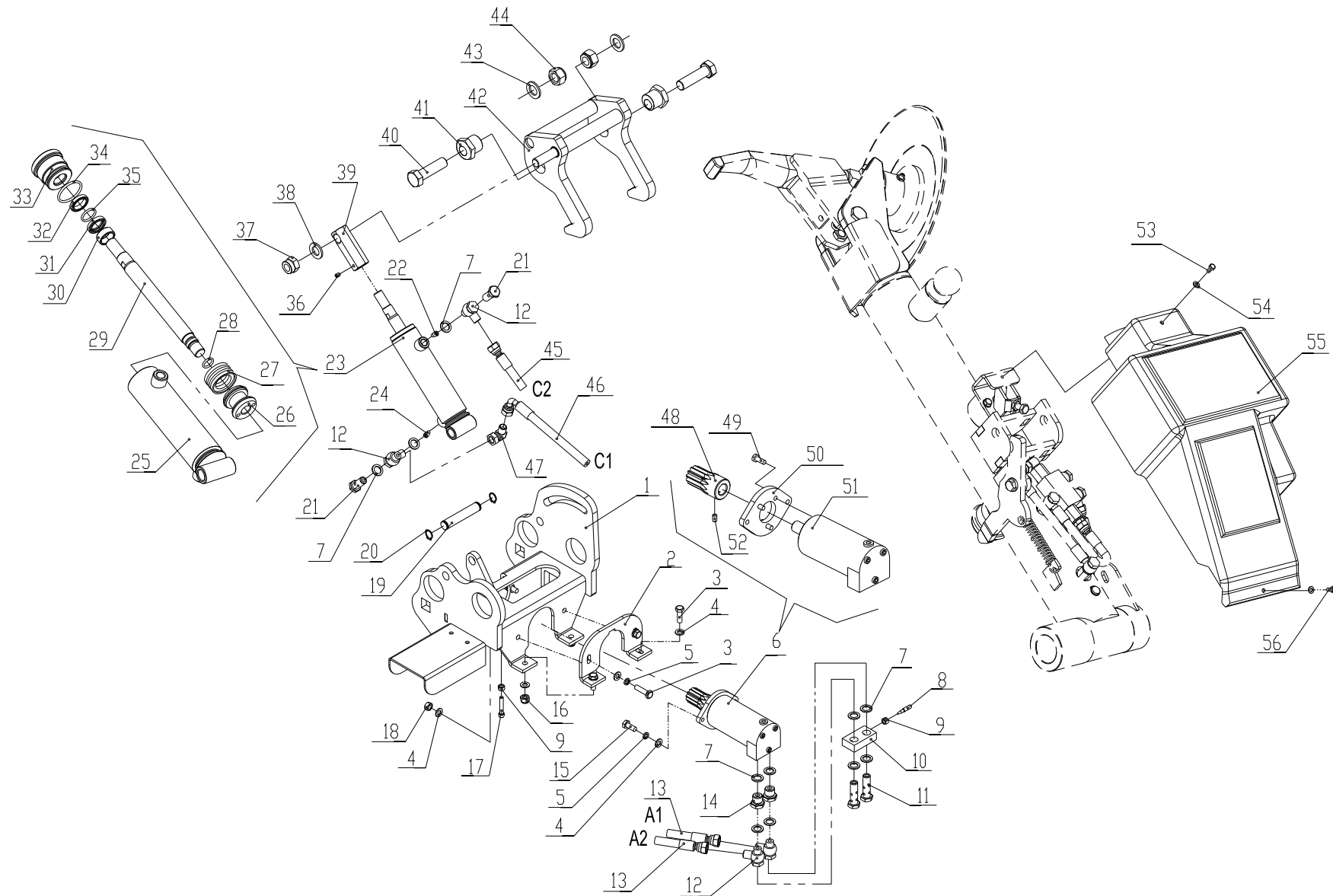

TAV.12.0	TOOL ARM SADDLE	ED. 11/11
----------	-----------------	-----------

ITEM	PART NO.	DESCRIPTION	QTY	REMARK
1	C56B321000	Arm trolley	1	
2	C56B320008	Upper support plate	1	
3	0201031	Screw M8X30	4	
4	0205008	Washer D.8	10	
5	0208006	Spring washer D.8	4	
6	C56B323000	Hydraulic motor unit	1	
7	0313001	Washer 1/4	11	
8	YF611003	Flow restricting pin M6	1	
9	0203029	Nut M6	2	
10	C56BY88001	Flow delivery block	1	
11	C56BY88002	Drilled union bolt 1/4	2	
12	0304010	Rotation union 1/4	4	
13	C56BZW53000	Hydraulic hose L=5000	2	
14	0305044	Reduction union M.3/8 – F.1/4	2	
15	0201042	Screw M8X20	2	
16	0204004	Self-locking nut M8	2	
17	0202027	Screw M6X35	1	
18	0203029	Nut M8	2	
19	C56B320004	Cylinder pin	1	
20	0212002	Seeger D.16	2	
21	BZ-720B-0401	Special screw	2	
22	BZ-GZ-003	Special screw M8X12	2	
23	C56BY50000	Tool hooking cylinder	1	
24	BZ-GZ-002	Special screw M8X12	1	
25	C56BY52000	Cylinder liner	1	
26	216-40A801	Piston	1	
27	0312026	Gasket 40X26	1	

TAV.12.0	TOOL ARM SADDLE	ED. 11/11
----------	-----------------	-----------

28	0309019	O-ring 18X2.4	1
29	C56BY54001	Cylinder shaft	1
30	0305007	Guiding ring 20X10X2.5	1
31	0310006	Sealing ring 20X28X5.7	1
32	0311022	Scraper D.20	1
33	YF668002	Cylinder guiding cover	1
34	0309028	O-ring 40X3.1	1
35	0309022	O-ring 24X2.4	1
36	0209037	Screw M6X10	2
37	0204008	Self-locking nut M16	1
38	0205020	Washer D.16	1
39	C56B320010	Cylinder shaft top end	1
40	0201128	Screw M18X65	2
41	C56B320002	Cam	2
42	C56B322000	Arm hook	1
43	0205021	Washer D.18	2
44	0204009	Self-locking nut M18	2
45	C56BZW5150	Hydraulic hose L=5150	1
46	C56BWW5000	Hydraulic hose L=5000	1
47	0303073	90° union 1/4	1
48	C56B323001	Gear	1
49	0201012	Screw M6X16	3
50	C56B323002	Motor support	1
51	0307112	Hydraulic motor MM S 50 C	1
52	0209018	Screw M6X10	2
53	0201011	Screw M6X12	2
54	0205006	Washer D.6	2

TAV.12.0	TOOL ARM SADDLE	ED. 11/11
----------	-----------------	-----------

55	C56B410004	ABS cover	1
56	0202034	Screw M6X25	1

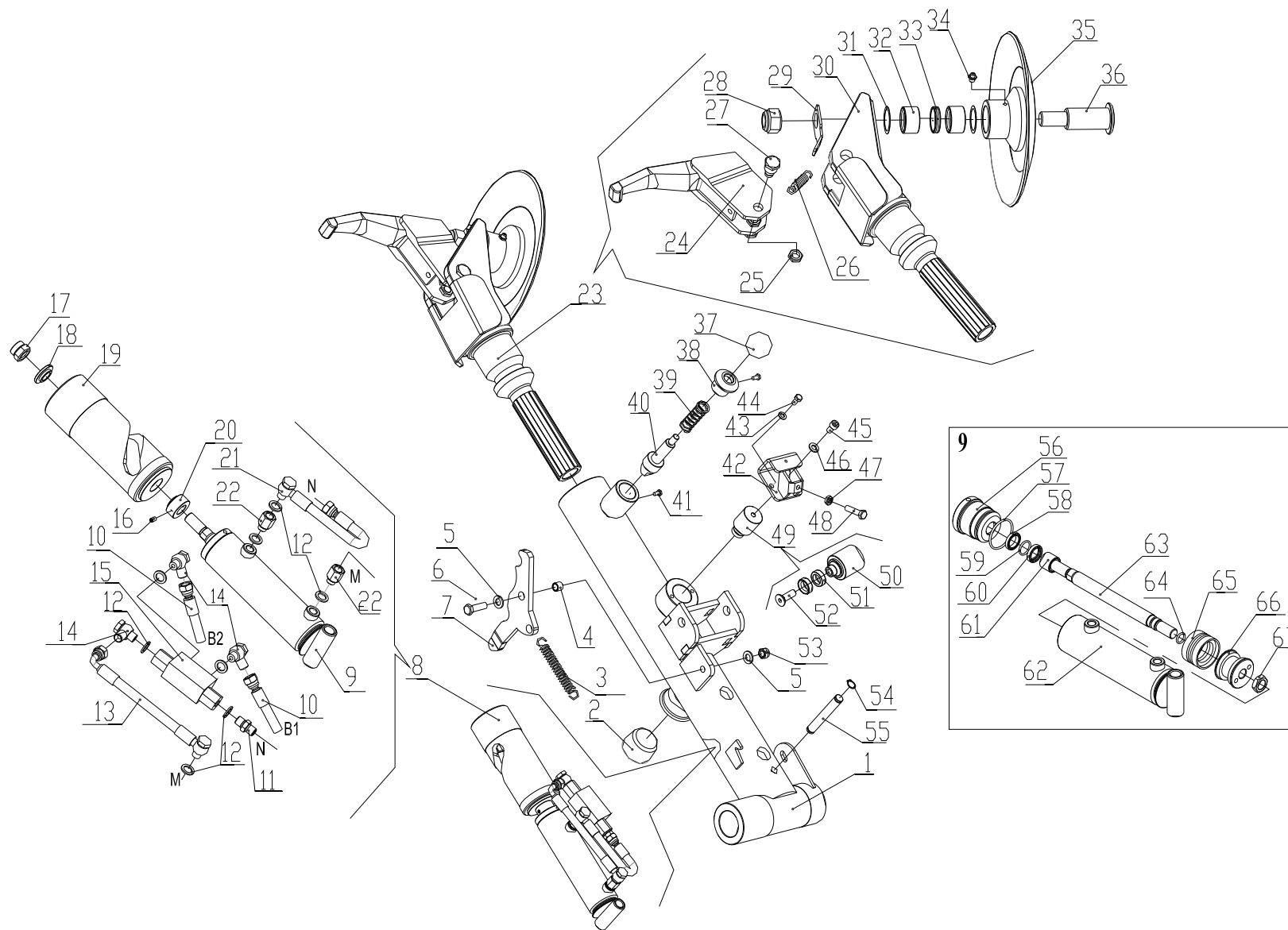

TAV.13.0	TOOL HOLDER ARM	ED. 11/11
----------	-----------------	-----------

ITEM	PART NO.	DESCRIPTION	QTY	REMARK
1	C56B411000	Tool arm	1	
2	C56B410003	Shock absorber	1	
3	YC1-3000114A	Arm spring	1	
4	C56B320003	Bush	1	
5	0205013	Washer D.12	2	
6	0201148	Screw M12X40	1	
7	C56B320009	Arm lever	1	
8	C56B414000	Rotation hub unit	1	
9	C56BY60000	Rotation cylinder	1	
10	C56BZW5330	Hydraulic hose L=5330	2	
11	0302007	Union 1/4	1	
12	0313001	Washer 1/4	8	
13	C56BWJ170X	Hydraulic hose L=170	1	
14	0304010	Rotation union 1/4	3	
15	0307042	Stop valve	1	
16	0209037	Screw M6X10	2	
17	0204008	Self-locking nut M16	1	
18	C56B414001	Spacer	1	
19	C56B414100	Rotation hub	1	
20	C56B414002	Spacer	1	
21	C56BZJ330X	Hydraulic hose L=330	1	
22	C56BY88003	Ferrule	2	
23	C56B420000	Double tool	1	
24	YC8-1000835	Long mounting tool	1	
25	0204014	Nut M16X1.5	2	
26	CC-620005	Spring	1	
27	YC8-3010837	Pin	2	

28	0204011	Self-locking nut M27	1
29	C56B420001	Spring connection	1
30	C56B421000	Tool support	1
31	YC8-4396915	Steel shim	2
32	CC-620002	Bead breaking disk bush	2
33	CC-620003	Spacer	1
34	0215020	Greaser 10X1	1
35	C56B422000	Bead breaking disk	1
36	CC-620001	Pin	1
37	C56B412004	Plastic knob	1
38	C56B412002	Bush	1
39	C56B412003	Spring	1
40	C56B412001	Pin	1
41	0201011	Screw M6X12	2
42	C56B415000	Support	1
43	0205008	Washer D.8	2
44	0201026	Screw M8X16	2
45	0202056	Screw M10X16	1
46	0205011	Washer D.10	1
47	0204012	Nut M10	1
48	0201068	Screw M10X40	1
49	C56B413000	Roller unit	1
50	C56B413001	Roller pin	1
51	C56B413002	Roller	2
52	0207047	Screw M10X30	1
53	0204007	Self-locking nut M12	1
54	0212002	Seeger D.16	2

55	C56B410001	Rotation cylinder pin	1
56	C56BY68005	Cylinder guiding cover	1
57	0309030	O-ring 50X3.1	1
58	0311022	Scraper D.20	1
59	0309022	O-ring 24X2.4	1
60	0310006	Sealing ring 20X28X5.7	1
61	GB/T15242.2	Guiding ring 20X20X2.5	1
62	C56BY62000	Cylinder liner	1
63	C56BY64001	Cylinder shaft	1
64	0309019	O-ring 18X2.4	1
65	0312010	Gasket 50X34X18.4	1
66	C56BY68002	Piston	1
67	0204014	Nut M16X1.5	1

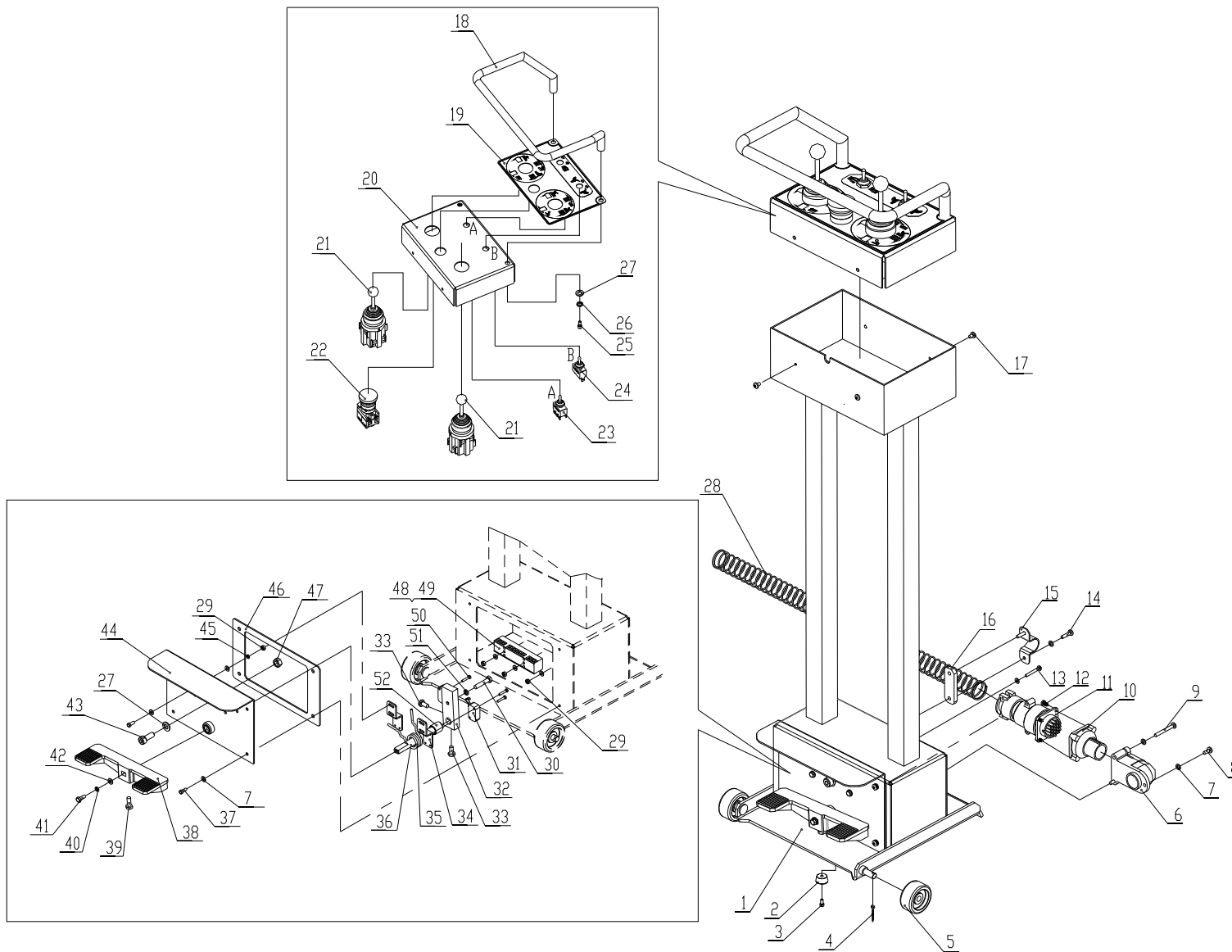

TAV.11.0	MOBILE CONTROL UNIT	ED. 11/11
----------	---------------------	-----------

ITEM	PART NO.	DESCRIPTION	QTY	REMARK
1	C56BD12100	Control unit post	1	
2	C56BD12004	Rubber foot	2	
3	0202015	Screw M5X10	2	
4	GB/T91	Split pin 2X18	2	
5	C56BD12001	Wheel	2	
6	C56BD12301	Harness holder	1	
7	0205002	Washer D.4	25	
8	0206012	Screw M4X10	1	
9	0206022	Screw M4X35	2	
10	C56BD12302	Clamping flange	1	
11	0507165	Cable connector P32-19	1	
12	0207032	Self-tapping screw ST3.5X12	4	
13	0206018	Screw M4X30	4	
14	0206015	Screw M4X16	2	
15	YC8-3001069	U bolt	1	
16	C56BD10002	Plastic spacer	1	
17	0206023	Screw M4X6	4	
18	C56BD12200	Handle	1	
19	C56BD12401	Control decal	1	
20	C56BD12003	Control panel	1	
21	0505010	Manipulator	2	
22	0502044	Emergency stop button	1	
23	0505042	Switch 223	1	
24	0505016	Switch123	1	
25	0202040	Screw M8X16	2	
26	0208006	Spring washer D.8	2	
27	0205008	Washer D.8	3	

TAV.11.0	MOBILE CONTROL UNIT	ED. 11/11
----------	---------------------	-----------

28	C56BD10001	Cable conduit	1
29	0203002	Nut M4	8
30	0201019	Screw M6X30	1
31	0505014	Micro switch	2
32	YC8-3001131	Lever	1
33	0201010	Screw M6X12	2
34	YC8-3001143a	Switch support	2
35	YC8-3007133b	Pedal control spring	1
36	YC8-3015413	Spring support	1
37	0201001	Screw M4X10	8
38	YC8-3015412	Pedal	1
39	0201012	Screw M6X16	1
40	0208003	Spring washer D.5	1
41	0201006	Screw M5X12	1
42	0205004	Washer D.5	1
43	0202045	Screw M8X20	1
44	YC8-2400977	Pedal box	1
45	0208002	Spring washer D.4	8
46	YC8-3001138	Gasket	1
47	0203008	Nut M8	1
48	0507013	Terminal board 6	1
49	0507009	Terminal board12	1
50	0206002	Screw M3X16	4
51	0208005	Spring washer D.6	1
52	YC8-3001135	Spacer	1

ACCESSORIES

ED. 10/11

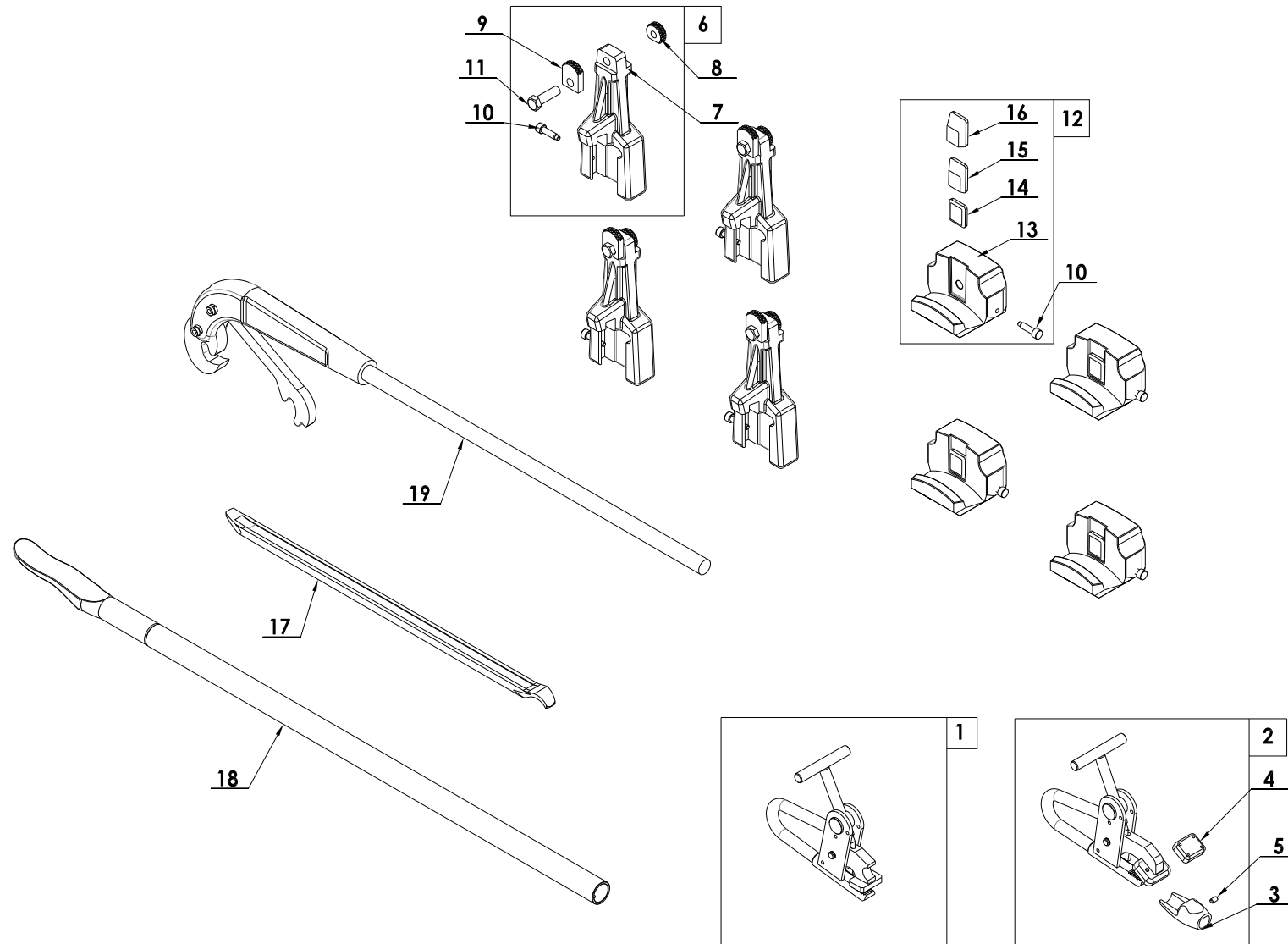

ACCESSORIES

ED. 10/11

ITEM	PART NO.	DESCRIPTION	QTY	REMARK
1	DB-11	Pliers	1	
2	YC8-F200000	Pliers for alloy rim Art. 138/90	1	Optional
3	YC8-F202001	Alloy protection	1	
4	YC8-F201001	Block	1	
5	0209037	Screw M6X10	1	
6	YC8-F100200	Clamping extension kit Art. 140/90	4	Optional
7	YC8-F100201	Clamping extension	1	
8	YC8-F100202	Short clamp	1	
9	YC8-F100203	Long clamp	1	
10	YC8-F100105	Special screw	2	
11	0201148	Screw M12X40	1	
12	YC8-F100100	Clamp protection kit Art. 137/90	4	Optional
13	YC8-F100101	Clamp protection	1	
14	YC8-F100102	Plastic insert 1	1	
15	YC8-F100103	Plastic insert 2	1	
16	YC8-F100104	Plastic insert 3	1	
17	0511040	Short tire lever 24"	1	
18	DB-12T	Long bead lifting lever	1	
19	0511009	Tire ring lifting lever Art. 148/90	1	Optional