

ED. 11/2016

**PART CATALOGUE**  
**STD-7230AG2**  
**SCISSOR LIFT**

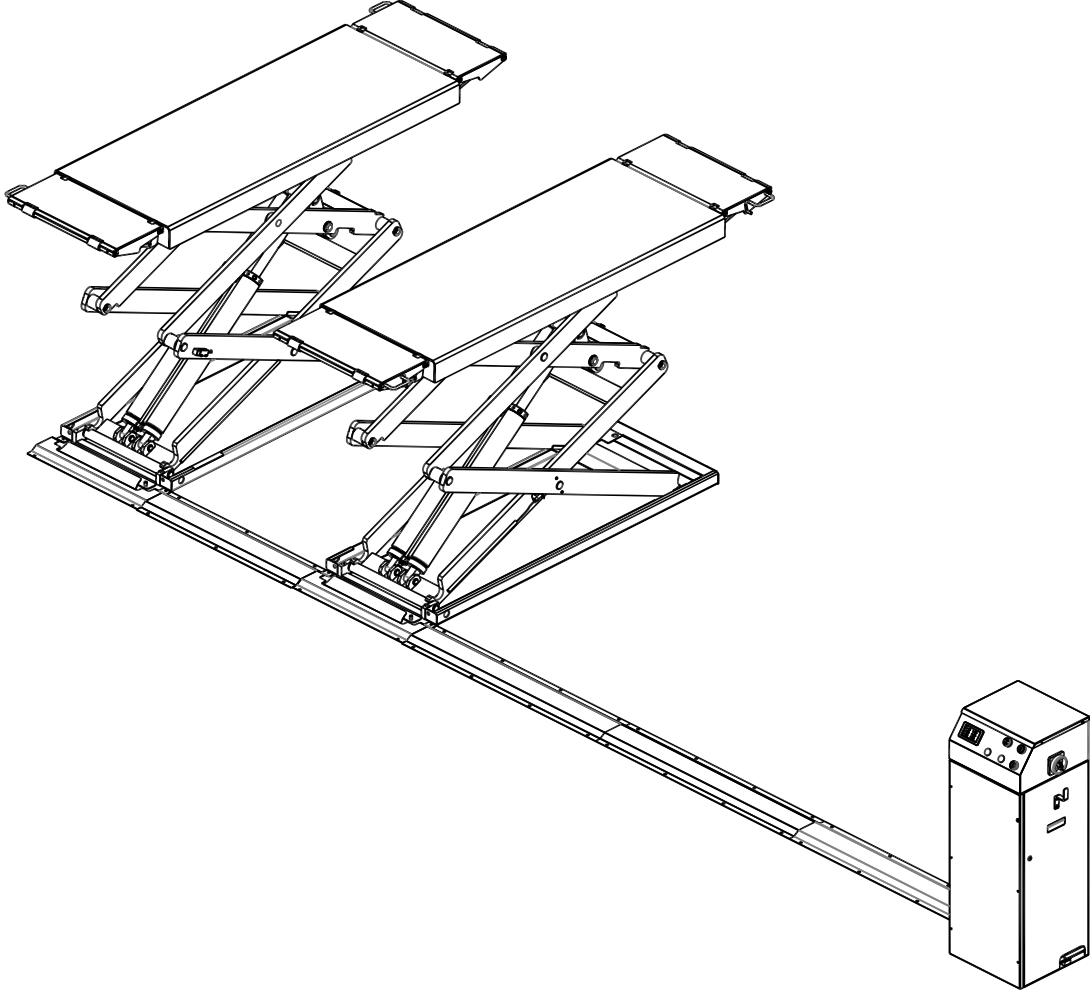

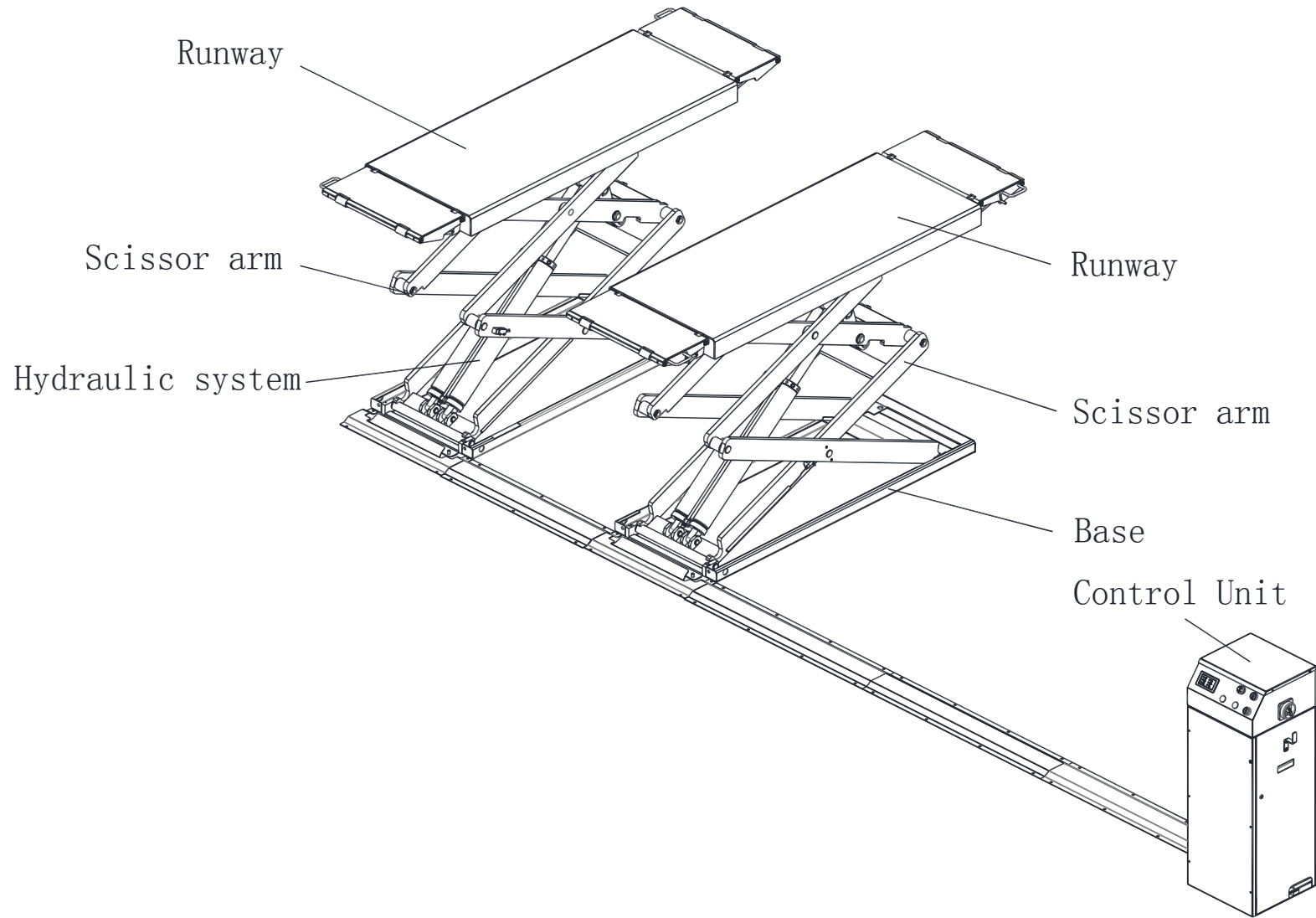

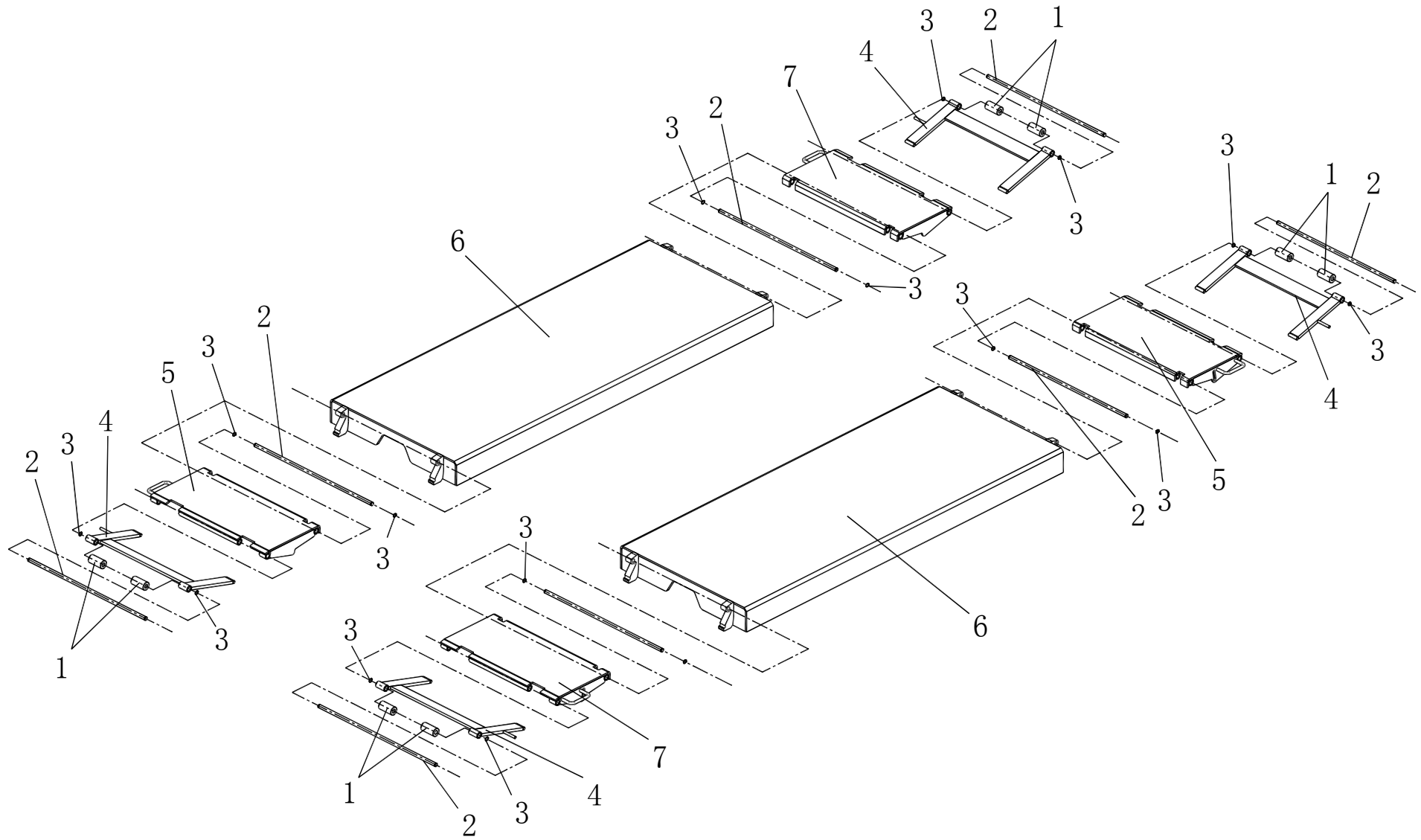

TAV.1	RUNWAY	ED. 11/2016
-------	--------	-------------

ITEM	PART NO.	DESCRIPTION	QTY	REMARK
1	YA20-0464	Roller	8	
2	YA20-0463	Shaft	8	
3	0212001	Seeger D.12 - GB/T894.1	16	
4	YA10-1235	Locking plate	4	
5	YA10-1234	Ramp 2	2	
6	YA10-1289T	Table	2	
7	YA10-1316	Ramp 1	2	

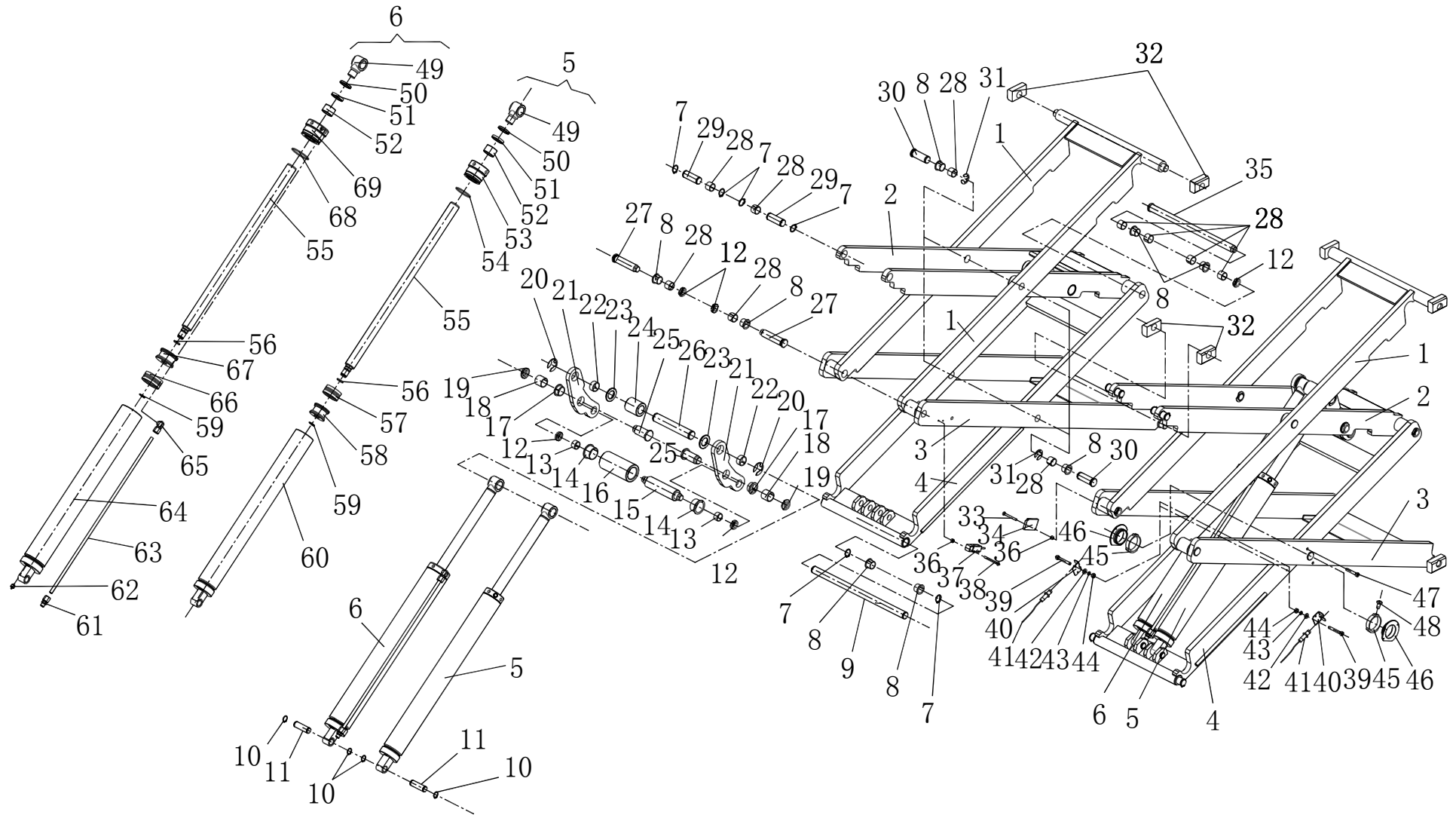

TAV.2	SCISSOR ARM	ED. 11/2016
-------	-------------	-------------

ITEM	PART NO.	DESCRIPTION	QTY	REMARK
1	YA10-1286T	Superior outer scissor	2	
2	YA10-1287T	Superior inner scissor	2	
3	YA10-1285B-G	Inferior outer scissor	2	
4	YA10-1284B-G	Inferior inner scissor	2	
5	YA-60-0	Slave hydraulic cylinder	2	
6	YA-70-0	Master hydraulic cylinder	2	
7	0212004	Seeger D.25 - GB/T894.2	12	
8	0210041	Edged self-lubricated bush 2520	20	
9	YA20-0478	Shaft	2	
10	0212005	Seeger D.20 - GB/T894.2	8	
11	YA20-0476T	Cylinder lower shaft	4	
12	0204059	Nut M20X1 - GT/T812	10	
13	0210039	Self-lubricated bush 2515	4	
14	0210043	Edged self-lubricated bush 4025	4	
15	YA20-0592	Shaft	2	
16	YA20-0483	Bush	2	
17	0210042	Edged self-lubricated bush 3015	4	
18	0210015	Self-lubricated bush 3030	4	
19	0204060	Nut M25X1.5 - GB/T6184	4	
20	0211019	Seeger D.24 - GB/T896	4	
21	YA10-1288	Lever	4	
22	0210040	Self-lubricated bush 3015	4	
23	YA20-0615T	Spacer	4	
24	YA20-0481T	Nylon spacer	2	
25	YA20-0593	Shaft	4	
26	YA20-0477	Cylinder upper shaft	2	
27	YA20-0474	Shaft	4	

TAV.2	SCISSOR ARM	ED. 11/2016
-------	-------------	-------------

28	0210008	Self-lubricated bush 2520	24	
29	YA20-0479	Shaft	4	
30	YA20-0472	Shaft	8	
31	0211003	Seeger D.19 - GB//T896	8	
32	YA20-0473	Nylon slider	8	
33	0206005	Screw M3X30- GT/T818	2	
34	0505057	Photo reflector (40X60)	1	Special request
35	YA20-0480	Shaft	2	
36	0204058	Nut M3- GB/T889.1	4	
37	0505057	Photocell (PEX-EC19NC1MD)	1	Special request
38	0206066	Screw M3X50- GT/T818	2	
39	0202006	Screw M4X30 - GB/T70.1	4	
40	YA10-2001T	Switch support	2	
41	0505061	Proximity switch	2	
42	0205002	Washer D.4 - GB/T97.1	4	
43	0208002	Spring washer D.4 - GB/T93	4	
44	0203002	Nut M4 - GB/T6170	4	
45	YA10-2003T	Limit ring	2	
46	YA10-2002T	Ring support	2	
47	0202005	Screw M4X25 - GB/T70.1	4	
48	0206024	Screw M5X10 - GB/T818	2	
49	YA-70-6	Shaft support	2	
50	0311016	Scraper 36X44X5	2	
51	0310031	Seal 36X46X8	2	
52	0305006	Guide ring 36X25X2.5 - GB/T15242.2	2	
53	YAY-60-5	Cylinder guiding cover	1	
54	0309032	O-ring 60X3.1 - GB1235	1	

TAV.2	SCISSOR ARM	ED. 11/2016
-------	-------------	-------------

55	YA-70-4	Cylinder shaft	2
56	0309022	O-ring 24X2.4 - GB1235	2
57	0312027	Gasket 60X48X20.5	1
58	YAY-60-3	Piston	1
59	0212005	Seeger D.20 - GB/T894.2	2
60	YAY-60-10	Slave cylinder liner	1
61	0303078	Union 1CB-16-04RN	1
62	0307022	Parachute valve V389201A11 - G1/4	1
63	YA-70-7	Oil pipe	1
64	YAY-70-10	Master cylinder liner	1
65	0303079	Union 1CT9-16-04RN	1
66	0312028	Gasket 70X58X20.5	1
67	YAY-70-3	Piston	1
68	0309050	O-ring 70X3.1 - GB1235	1
69	YAY-70-5	Cylinder guiding cover	1



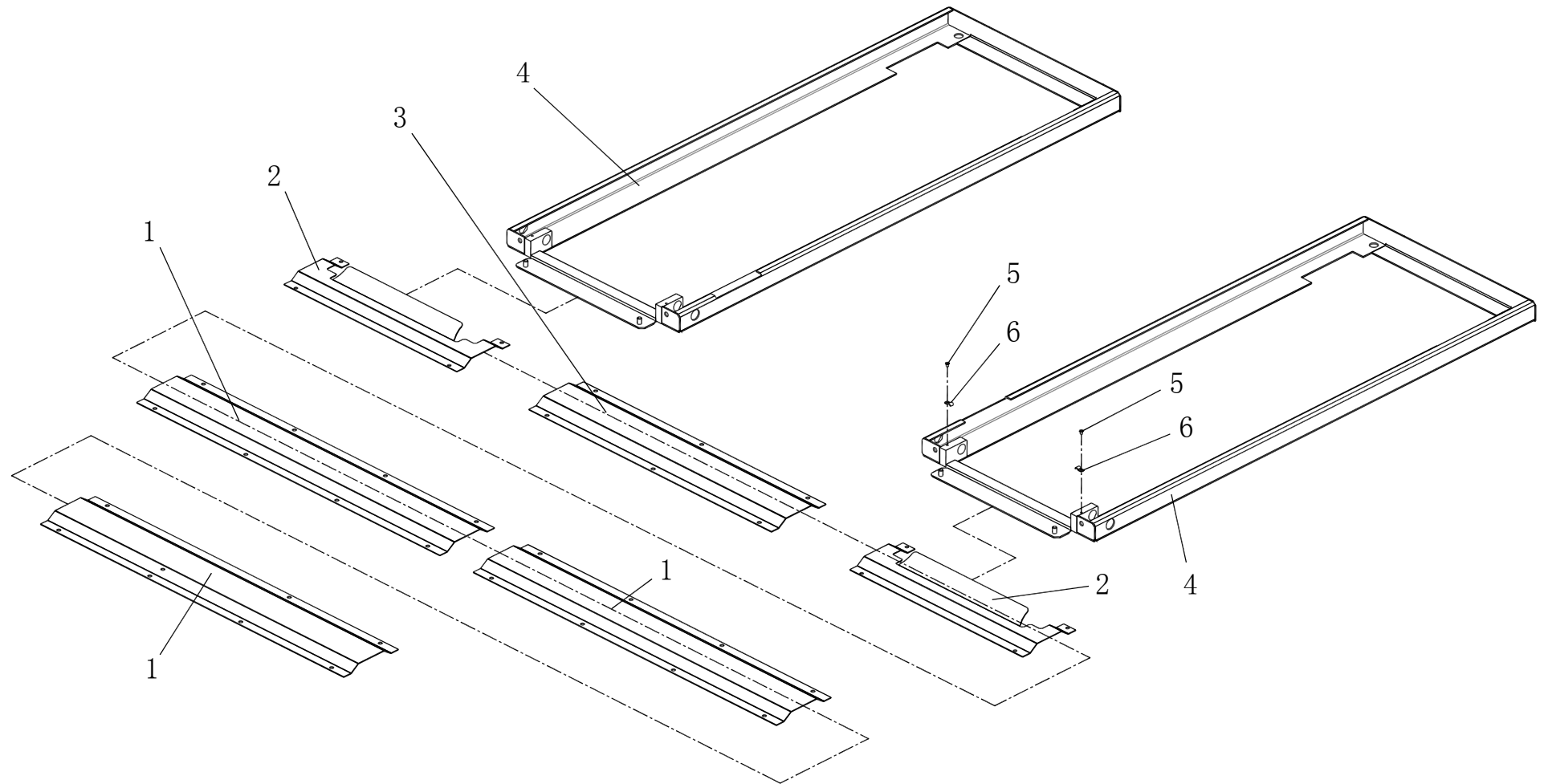

TAV.3	BASE	ED. 11/2016
-------	------	-------------

ITEM	PART NO.	DESCRIPTION	QTY	REMARK
1	YA10-1298.02	Hose cover	3	
2	YA10-1298.05	Hose cover	2	
3	YA10-1298.01	Hose cover	1	
4	YA10-1283-G	Base	2	
5	0207007	Screw M5X8- GB/T819.1	2	
6	YA10-2004T	U bolt	2	

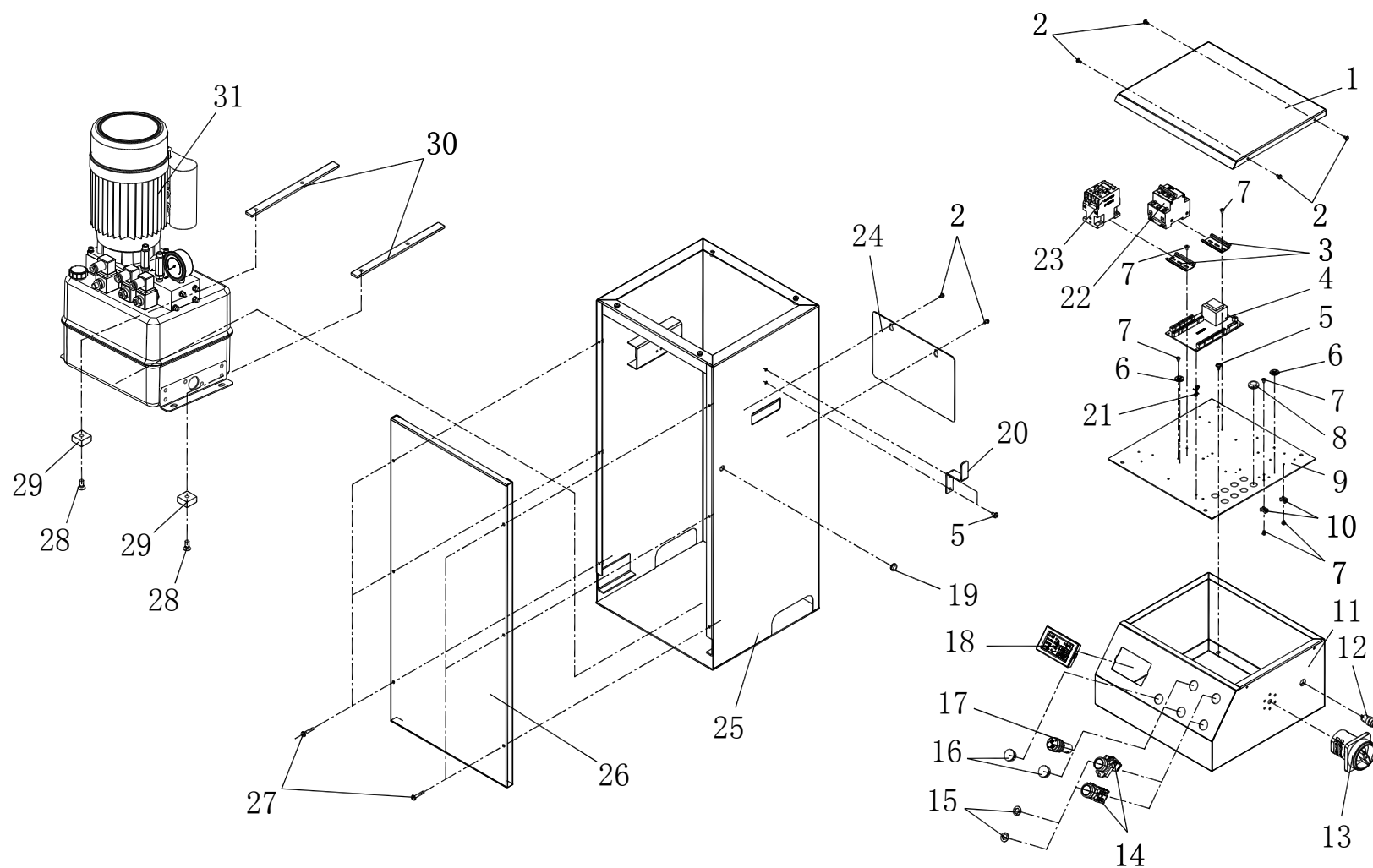

TAV.4	CONTROL UNIT	ED. 11/2016
-------	--------------	-------------

ITEM	PART NO.	DESCRIPTION	QTY	REMARK
1	J04A030002	Panel cover	1	
2	0206059	Screw M4X12	6	
3	0508330	Guide DZ47 L=60mm	2	
4	0507367	CPU board 102.1	1	
5	0206058	Screw M5X10	6	
6	0510380	Grounding decal	2	
7	0206019	Screw M4X6 - GB/T818	10	
8	0508017	Cable relief	8	
9	J04A110001	Support	1	
10	0508018	Holder HC-1(Φ4)	2	
11	J04A113000	Top box	1	
12	0502017	Pushbutton LA16Y-11-Y	1	
13	0505022	Power switch HZ5-2-20A	1	
14	0502024	Pushbutton LAY37T-10	2	
15	0510196	Up decal	2	
16	0508019	Plug HP-22	2	
17	0502021	Buzzer AD16-22SM(AC、DC24V)	1	
18	0507163	Function display 502D	1	
19	0508013	Cable relief GM-1710	1	
20	3002002009	Cable holder	1	
21	0508302	Holder HDB-16A	4	
22a	0501066	Breaker DZ47-63/3P-D16A	1	For 380V/3ph
22b	0501074	Breaker DZ47-63/3P-D32A	1	For 220V/1ph
23	0501001	AC contactor CJX2-1210 (AC220V)	1	
24	3054503904	Back cover	1	
25	J04A031000	Lower box	1	
26	J04A030003	Front cover	1	

TAV.4	CONTROL UNIT		ED. 11/2016
-------	--------------	--	-------------

27	0206028	Screw M5X25	6
28	0207019	Screw M8X20 - GB/T819.1	4
29	3032084008	Rubber pad	4
30	3002005001	Support	2
31	BZ-W2K2Y	Hydraulic power unit	1

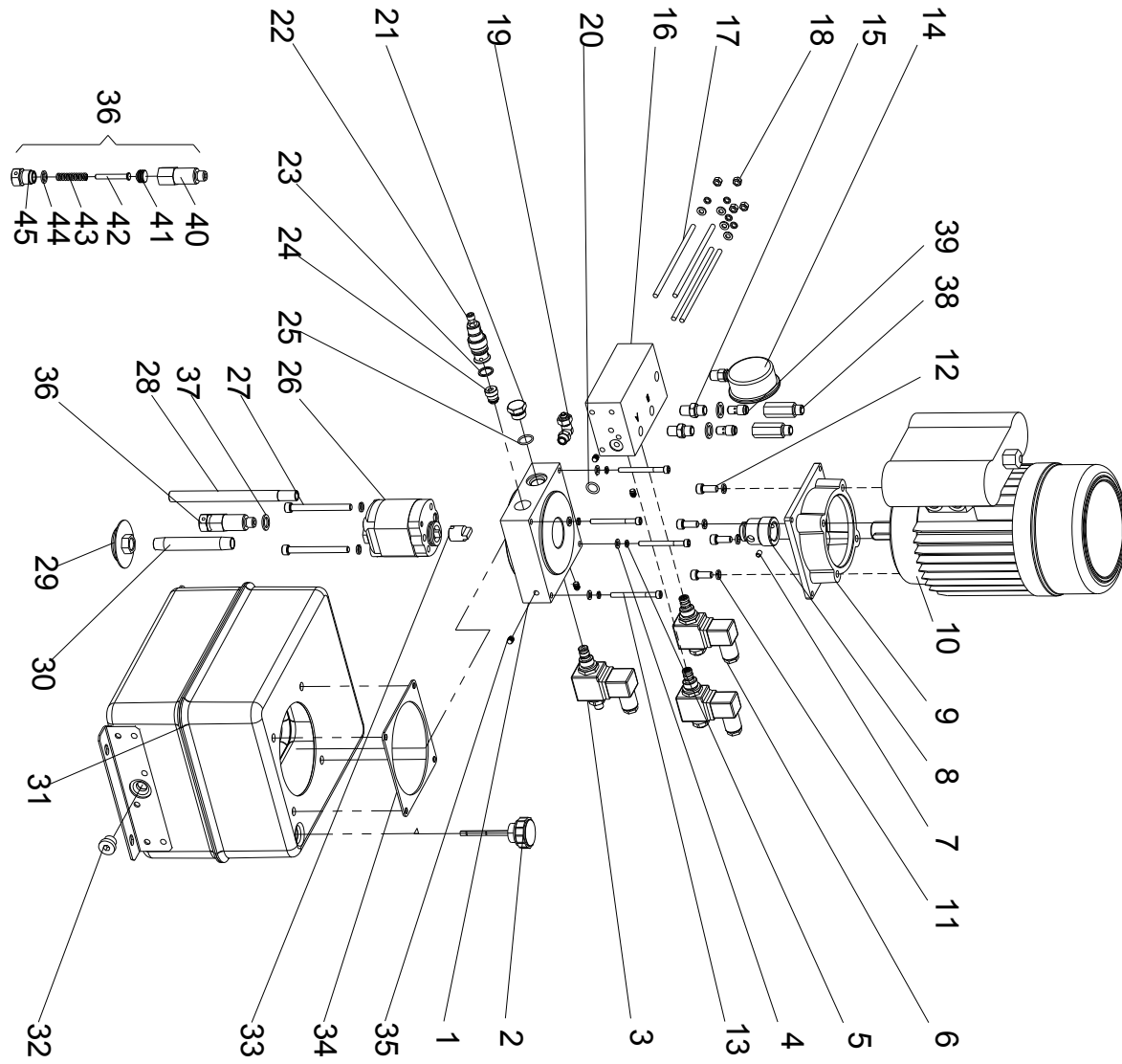

TAV.4.1	HYDRAULIC POWER UNIT	ED. 11/2016
---------	----------------------	-------------

ITEM	PART NO.	DESCRIPTION	QTY	REMARK
1	BZ-ZB-W2	Manifold	1	
2	0305087	Oil level plug G3/4"	1	
3	0307049	Lowering solenoid valve (220V)	1	
4	0205006	Washer D.6 - GB/T97.1	8	
5	0208005	Spring washer D.6 - GB/T93	8	
6	0307043	Solenoid valve (220V)	2	
7	0209042	Screw M6X8 - GB/T80	1	
8	BZ-ZT24	Motor joint	1	
9	BZ-DJ-1B	Motor flange	1	
10a	0509070	Motor 380V/50Hz/3PH 2.6KW	1	
10b	0509071	Motor 220V/50Hz/1PH 2.2KW	1	
10c	0509092	Motor 220V/60Hz/1PH 2.2KW	1	
11	0208006	Spring washer D.8 - GB/T93	6	
12	0202045	Screw M8X20 - GB/T70.1	4	
13	0202036	Screw M6X65 - GB/T70.1	4	
14	0305054	Pressure gauge LA-60X400	1	
15	0303063	Union 1/4 1BT-04SP	2	
16	BZ-W-YK2Y	Interface block	1	
17	0213032	Double-screw bolt M6X160	4	
18	0203004	Nut M6-GB52	4	
19	0306067	Union 10 ZG1-4	1	
20	0309019	O-ring 18X2.4 - GB1235	1	
21	BZ-SD-01	Plug	1	
22	0307010	Pressure overload valve FYF06-01-00	1	
23	0313057	Copper washer 16X20	1	
24	0307067	Non return valve GDF-06-07-00	1	
25	0309054	O-ring 17X2	1	

TAV.5	HYDRAULIC POWER UNIT	ED. 11/2016
-------	----------------------	-------------

26a	0301054	Gear pump3.3CC	1	For 3PH motor
26b	0301041	Gear pump1.6CC	1	For 1PHmotor
27	0202052	Screw M8X85- GB/T70.1	2	
28	BZ-G14X180	Oil return pipe	1	
29	0305010	Oil filter ZG3/8" ZF-08	1	
30	BZ-G18X110	Oil suction pipe	1	
31	HK2-0200	Oil tank	1	
32	0305018	Plug 4BN-06WD G3/8	1	
33	BZ-BJ25	Pump joint	1	
34	BZ-F-01	Gasket	1	
35	0305001	Plug ZBJ22 007-QD07	4	
36	BZ-HC2-0	Starting valve	1	For 1PH motor
37	0313001	Washer BS/A13.70	3	For 1PH motor
38	7135-B	Union	2	
39	0307004	Lowering speed control valve BLF06-02-00/D1.2	2	
40	BZ-HC2-1	Valve body	1	For 1PH motor
41	BZ-HC-2	Valve piston	1	For 1PH motor
42	BZ-HC2-3	Valve pin	1	For 1PH motor
43	BZ-HC2-4	Spring	1	For 1PH motor
44	BZ-HC2-5	Valve back cover	1	For 1PH motor
45	BZ-HC-6	Seal 16X9X2.5	1	For 1PH motor



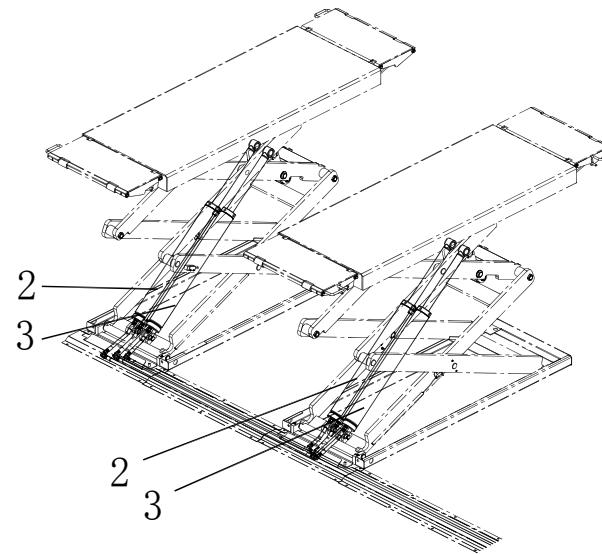
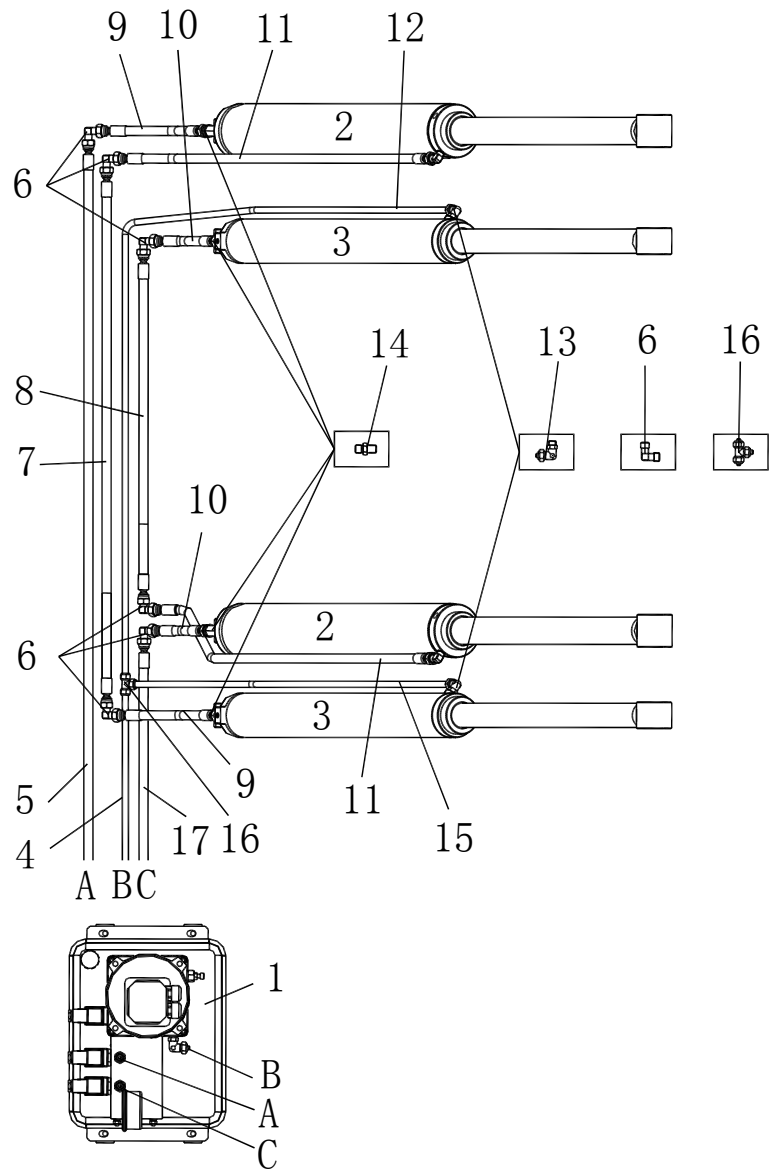

TAV.6

## HYDRAULIC CYLINDERS

ED. 11/2016

ITEM	PART NO.	DESCRIPTION	QTY	REMARK
1	BZ-W2K2Y	Hydraulic power unit	1	
2	YAY-70-0	Master hydraulic cylinder	2	
3	YAY-60-0	Slave hydraulic cylinder	2	
4	0306109	PU hose 10X6.5X3000C	1	
5	ZW4200	Hydraulic hose L=4200	1	
6	0303010	90° union 1B9-04SP	6	
7	ZZ1400	Hydraulic hose L=1400	1	
8	ZZ1300	Hydraulic hose L=1300	1	
9	ZZ210	Hydraulic hose L=210	2	
10	ZZ180	Hydraulic hose L=180	2	
11	ZZ195	Hydraulic hose L=195	2	
12	0306109	PU hose 10X6.5X2300C	1	
13	0306067	Union 10 ZG1-4	2	
14	0303063	Union 1/4 1BT-04SP	4	
15	0306109	PU hose 10X6.5X900C	1	
16	0306081	Tee union 10	1	
17	ZW2870	Hydraulic hose L=2870	1	