

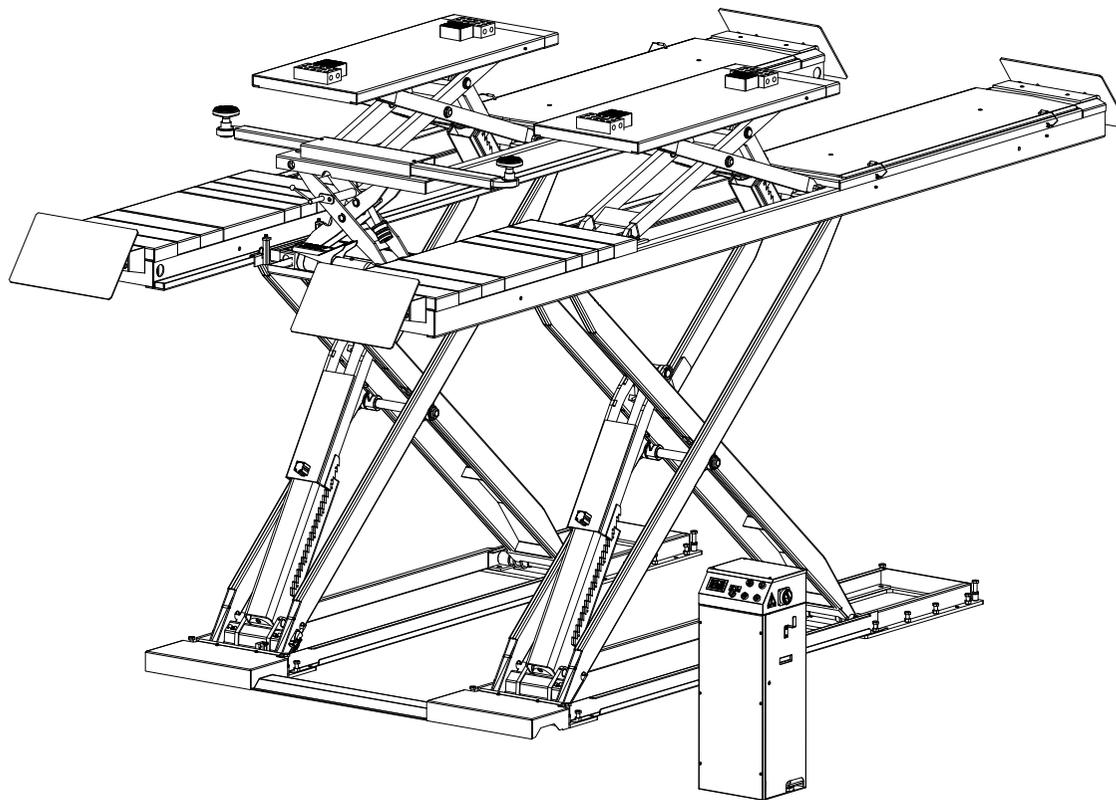

ED. 04/2016

PART CATALOGUE
STD-8250A1
SCISSOR LIFT FOR
ALIGNMENT

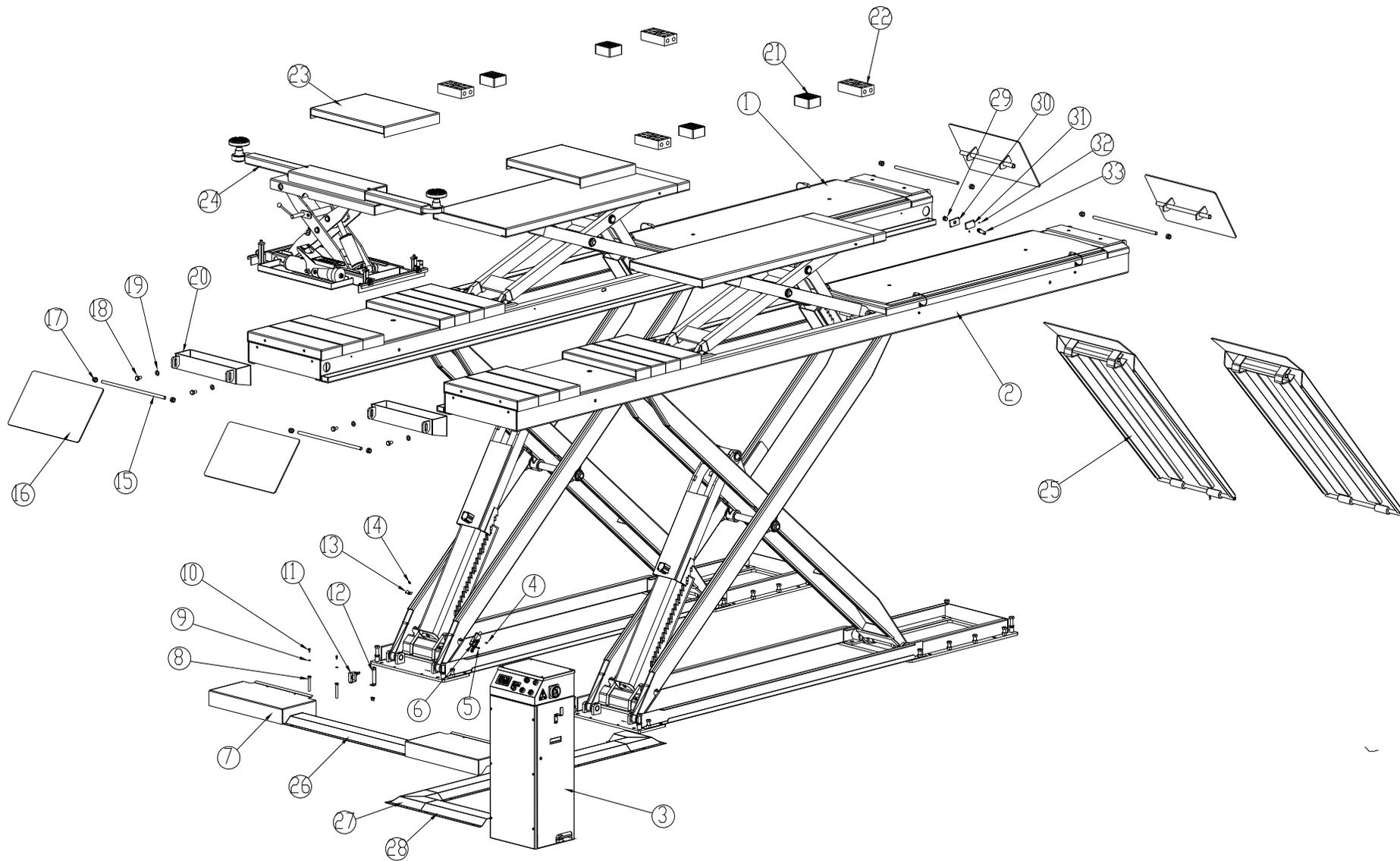



TAV.0	LIFT	ED. 04/16
-------	------	-----------

ITEM	PART NO.	DESCRIPTION	QTY	REMARK
1a	825D1-10000	Runway P1	1	For STD-8250D1
1b	825D -10000G	Runway P1	1	For STD-8250D
2a	825D1-20000	Runway P2	1	For STD-8250D1
2b	825D-20000G	Runway P2	1	For STD-8250D
3	8240D03000	Control unit	1	
4	0206013	Screw M4X12 - GB/T818	1	
5	0206017	Screw M4X25 - GB/T818	1	
6	0505018	Safety position limit switch8108	1	
7	824-000001	Front cover	2	
8	824-000002	Special screw M12X80	4	
9	0205006	Washer D.6- GB/T97.1	4	
10	0202024	Screw M6X12 - GB/T70.1	6	
11	0505017	Top position limit switch7311	1	
12	CJS30-01-04	Switch support	1	
13	8200-72	U bolt	3	
14	0202037	Screw M6X8 - GB/T70.1	3	
15	8200B6-800012	Ramp pin	4	
16	8200TX-007100	Short ramp	4	
17	0204008	Self-locking nut M16 - GB/T889.1	8	
18	0201085	Screw M14X25 - GB/T5781	4	
19	0205017	Washer D.14- GB/T97.1	4	
20	824-000100	Front ramp support	2	
21	0606033	Rubber pad 115X100X55	4	
22	0606032	Rubber pad 180X100X50	4	
23	8200TY-800002	Turntable recess cover	2	
24	J07Q	Jacking beam HJ-75B	1	Excluded in STD-8250D
25	8200B6-300000	Long ramp for on-ground installation	2	Optional

TAV.0	LIFT	ED. 04/16
-------	------	-----------

26	8240TX-000862	Front hose cover for on-ground installation	2	Optional
27	8240B-008640	Hose cover for on-ground installation	2	Optional
28	8240TX-000863	Hose corner cover for on-ground installation	1	Optional
29	8250-000085	Bolt	1	Optional
30	8250-000083	Reflector support board	1	Optional
31	DQ00001	Photocell reflector	1	Optional
32	0206009	Screw M3X6 - GB.T818	2	Optional
33	0505058	Photocell sensor	1	Optional

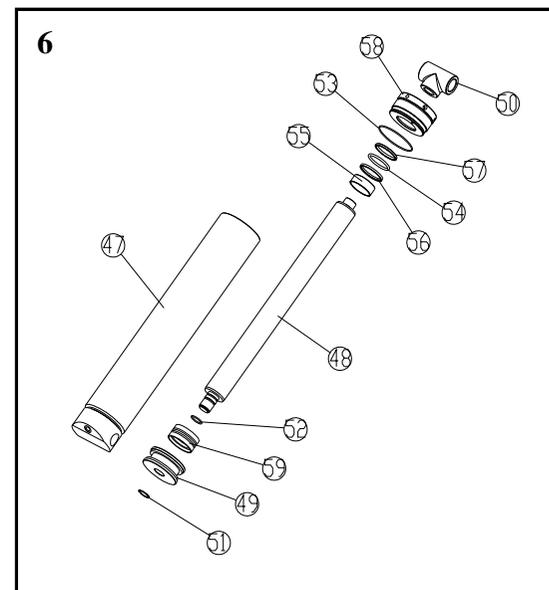
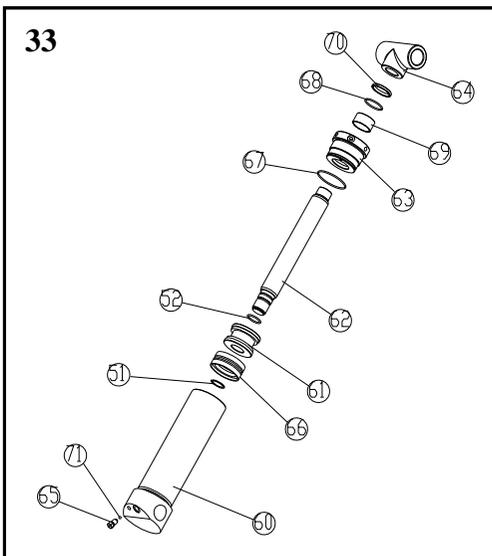
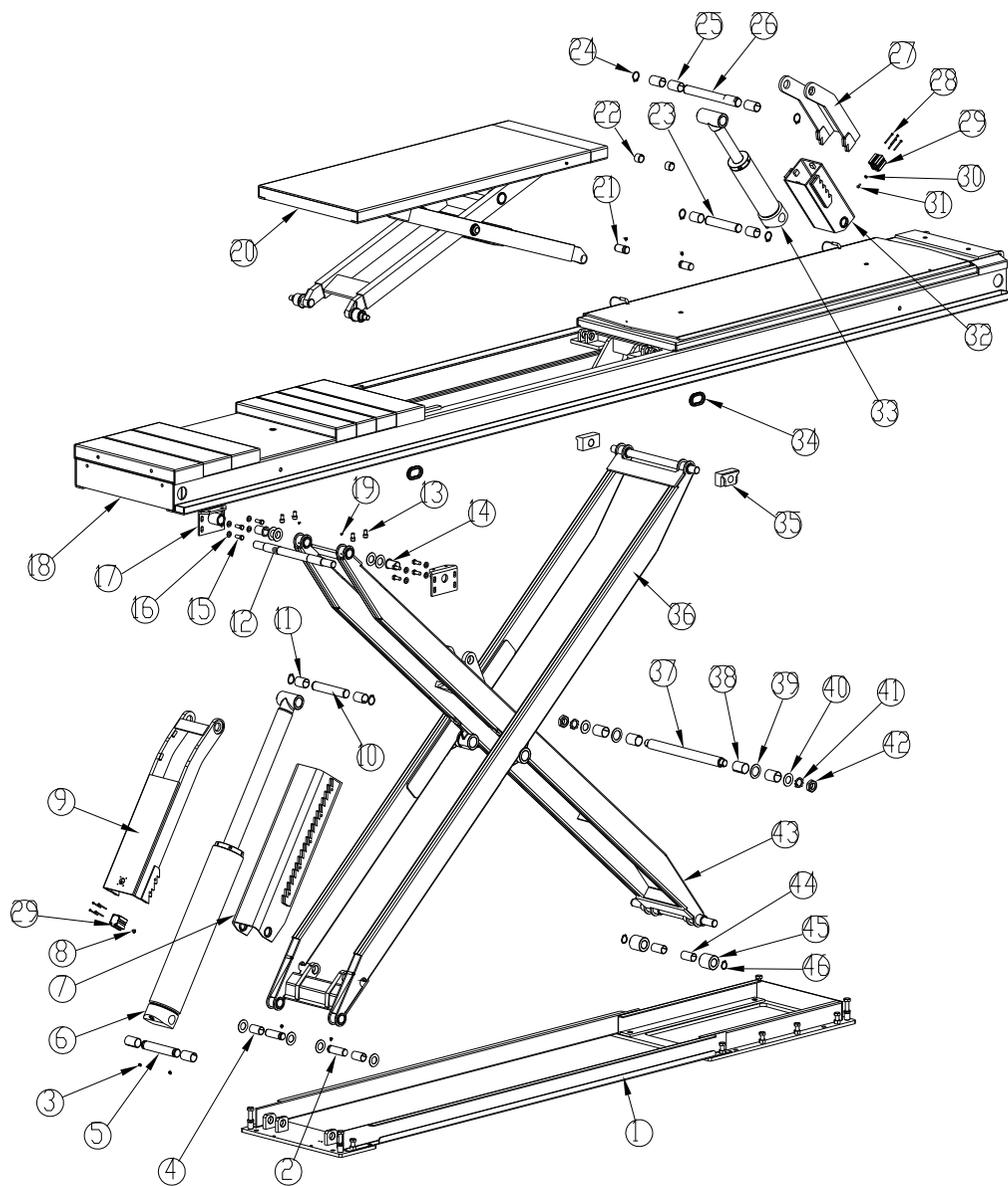

TAV.1.0	RUNWAY P1	ED. 04/16
---------	-----------	-----------

ITEM	PART NO.	DESCRIPTION	QTY	REMARK
1	824-110000G	Base	1	
2	824-100003	Lower shaft	2	
3	0209025	Screw M8X12 - GB/T79	6	
4	0210018	Self-lubricated bush 3055	2	
5	8250-02-01-17	Cylinder lower shaft	1	
6	8250-120-00	Master hydraulic cylinder	1	
7	8250-06-03	Lower safety rack	1	
8	0207043	Screw M6X10- GB/T973	1	
9	824-161000	Upper safety rack	1	
10	8250-02-01-18	Cylinder upper shaft	1	
11	0210027	Self-lubricated bush 3550	4	
12	824-100005	Upper shaft	1	
13	0202070	Screw M12X20- GB/T70.1	4	
14	0210075	Self-lubricated bush 3050F	2	
15	0201074	Screw M12X30 - GB/T5781	8	
16	0205013	Washer D.12- GB/T97.1	8	
17	824-17000	Arm bracket	2	
18a	825D1-140000	P1 platform assembly	1	For STD-8250D1
18b	825D-140000G	P1 platform assembly	1	For STD-8250D
19	0209010	Screw M6X10 - GB/T78	2	
20	824-150000G	Wheel free jack assembly	1	
21	8250-04-02-08	Jack lower shaft	2	
22	0210013	Self-lubricated bush 3024	2	
23	8250-06-01	Cylinder lower shaft	1	
24	0212022	Seeger D.35- GB/T894.1	6	
25	0210028	Self-lubricated bush 3560	6	
26	8250-07-01	Cylinder upper shaft	1	

TAV.1.0	RUNWAY P1	ED. 04/16
---------	-----------	-----------

27	8250-07-02	Jack upper safety rack	1
28	0202010	Screw M4X50- GB/T70.1	8
29	0306010	Air locking cylinder 32X23	2
30	0203004	Nut M6 - GB/T52	1
31	0201173	Screw M6X16- GB/T12	1
32	8250-07-06	Jack lower safety rack	1
33	8250-00D	P1 jack hydraulic cylinder	1
34	CXQ-61X5.5	Hose holder	2
35	824-100001G	Nylon slider	2
36	824-130000G	Outer scissor arm	1
37	824-100004	Middle shaft	1
38	0210080	Self-lubricated bush 4055	4
39	8250-18	Shim	2
40	ZJJ3-17	Shim	10
41	0205025	Teethed washer D.30 - GB/T858	2
42	0204015	Nut M30 - GB/T6172.1	2
43	824-120000G	Inner scissor arm	1
44	0210046	Self-lubricated bush 3060	2
45	8240B-02-02-16	Lower wheel	2
46	0212021	Seeger D.30- GB/T894.2	2
47	8250-120-10	Master cylinder liner	1
48	8240B-120-04	Cylinder shaft	1
49	GJ350-120A-5	Piston	1
50	8250-120-06	Shaft support	1
51	0212007	Seeger D.32 - GB/T894.1	2
52	0309027	O-ring 38X3.1	2
53	0309012	O-ring 120X3.1	1

TAV.1.0	RUNWAY P1	ED. 04/16
---------	-----------	-----------

54	0309040	O-ring 75X5.7	1
55	0305006	Guide ring 67X25X2.5	1
56	0310019	Seal 67X77X6	1
57	0311013	Scraper67X75X5	1
58	GJ350-120A-2	Cylinder guiding cover	1
59	0312007	Gasket 120X95X22.4	1
60	8250-80-40	PI jack cylinder liner	1
61	ZJJ40-02D	Piston	1
62	ZJJ40-04D	Cylinder shaft	1
63	ZJJ40-05D	Cylinder guiding cover	1
64	8250-06C	Shaft support	1
65	ZJJ40-07D	Air bleeding plug	1
66	0312016	Gasket 80X60X22.4	1
67	0309041	O-ring 80X3.1	1
68	0309030	O-ring 50X3.1	1
69	0305006	Guide ring 45X25X2.5	1
70	0311009	Scraper45X53X5	1
71	0215059	Steel ball D.6	1

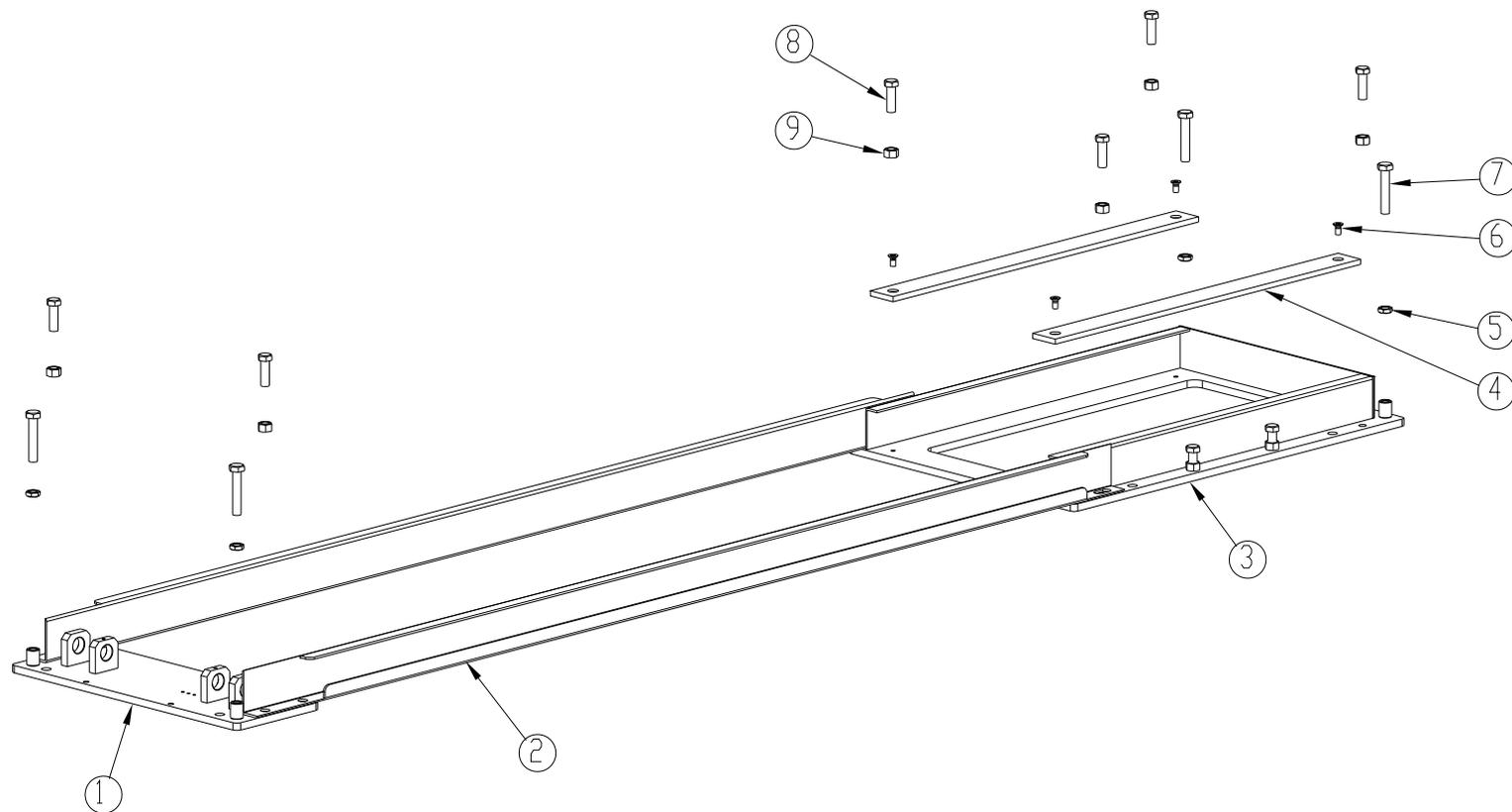

TAV.1.1	BASE	ED. 04/16
---------	------	-----------

ITEM	PART NO.	DESCRIPTION	QTY	REMARK
1	824-111000	Front base	1	
2	ZJJ3-0103	U connection rod	2	
3	824-112000	Rear base	1	
4	824-110001	Wheel guide	2	
5	0204032	Nut M16 - GB/T6172.1	4	
6	0207022	Screw M10X20- GB/T819.1	4	
7	0201180	Screw M16X85- GB/T5780	4	
8	0201103	Screw M16X50 - GB/T5781	10	
9	0203025	Nut M16 - GB/T6170	10	

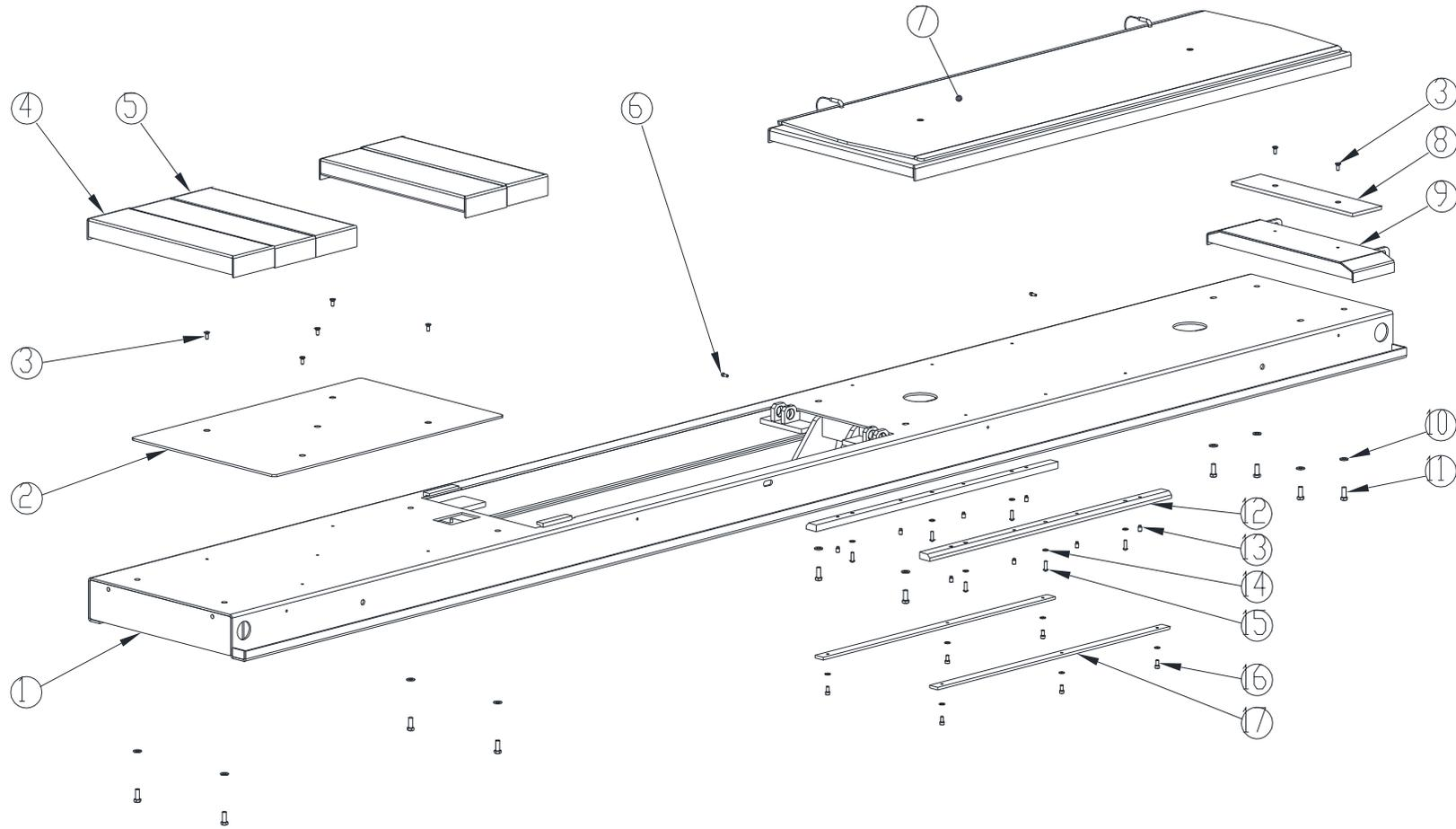

TAV.1.18	P1 PLATFORM ASSEMBLY	ED. 04/16
----------	----------------------	-----------

ITEM	PART NO.	DESCRIPTION	QTY	REMARK
1a	825D1-141000	P1 Platform	1	For STD-8250D1
1b	825D-141000G	P1 Platform	1	For STD-8250D
2	8240B4-000812	Turntable recess base plate	1	
3	0207036	Screw M8X20- GB/T70.3	7	
4	8240B4-03150A	Spacer	2	
5	8240B4-031501	Movable spacer	3	
6	0202032	Screw M6X16- GB/T70.1	2	
7	825D-145000	Slipping plate assembly	1	
8	825D-000001	Spacer	1	
9	825D-140100	Spacer	1	
10	0205013	Washer D.12 - GB/T97.1	10	
11	0201074	Screw M12X30 - GB/T5781	10	
12	824-140006	Upper wheel guide	2	
13	0209028	Screw M10X16 - GB/T79	8	
14	0205008	Washer D.8 - GB/T97.1	12	
15	0206037	Screw M8X25 - GB/T70.2	6	
16	0202040	Screw M8X16- GB/T70.1	6	
17	824-140007	Guide fastening plate	2	

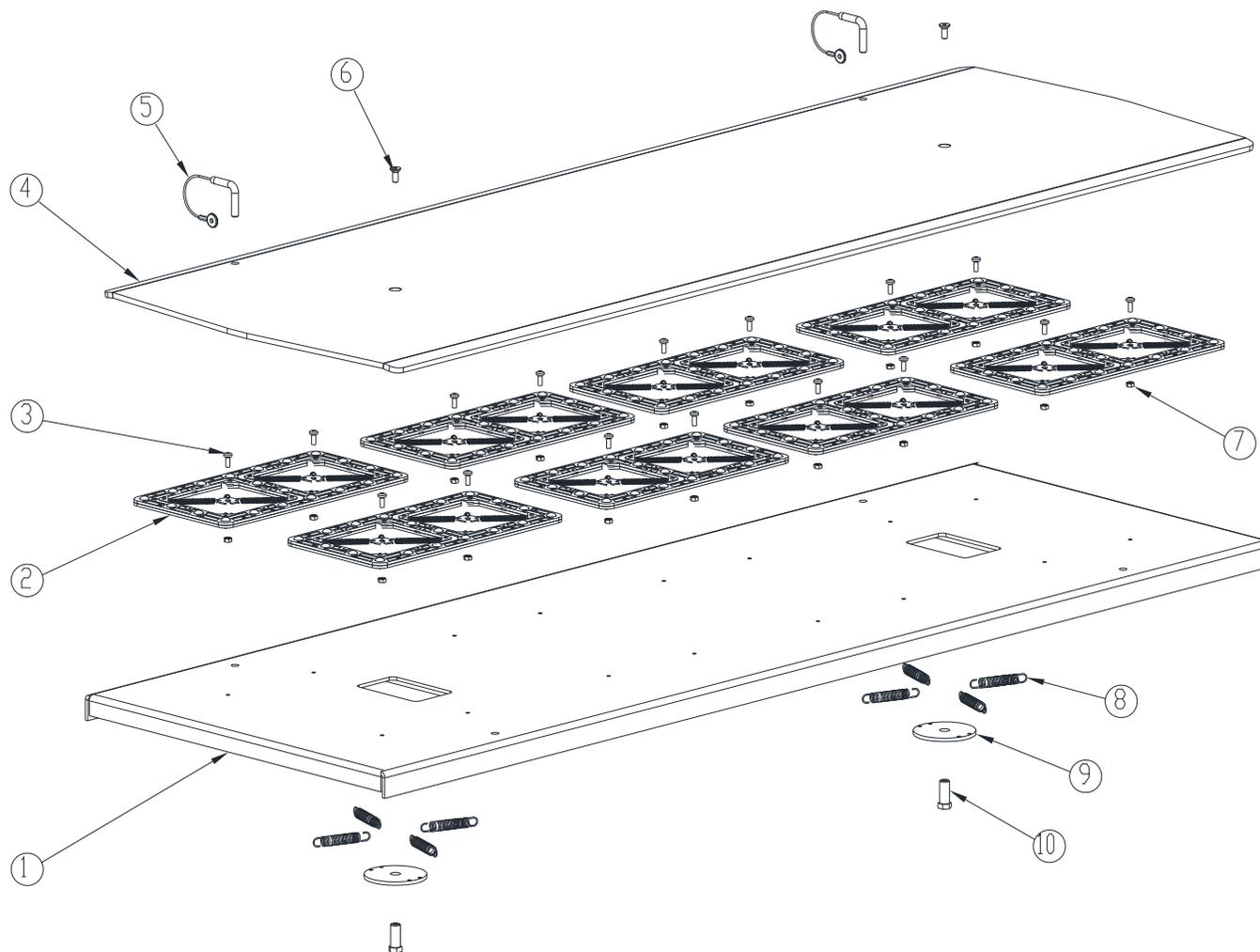

TAV.1.18.7

SLIPPING PLATE ASSEMBLY

ED. 04/16

ITEM	PART NO.	DESCRIPTION	QTY	REMARK
1	825D-145100	Base plate	1	
2	J63A332000	Roller gasket	8	
3	0206032	Screw M6X16 - GB/T818	16	
4	825D-142001	Slipping plate	1	
5	824B-142200	Stop pin	2	
6	0207036	Screw M8X20 - GB/T70.3	2	
7	0203004	Nut M6 - GB52	16	
8	XSZ-6-1	Spring	8	
9	824EH000382	Spring cradle	2	
10	824B-142003	Bolt - GB/T905	2	

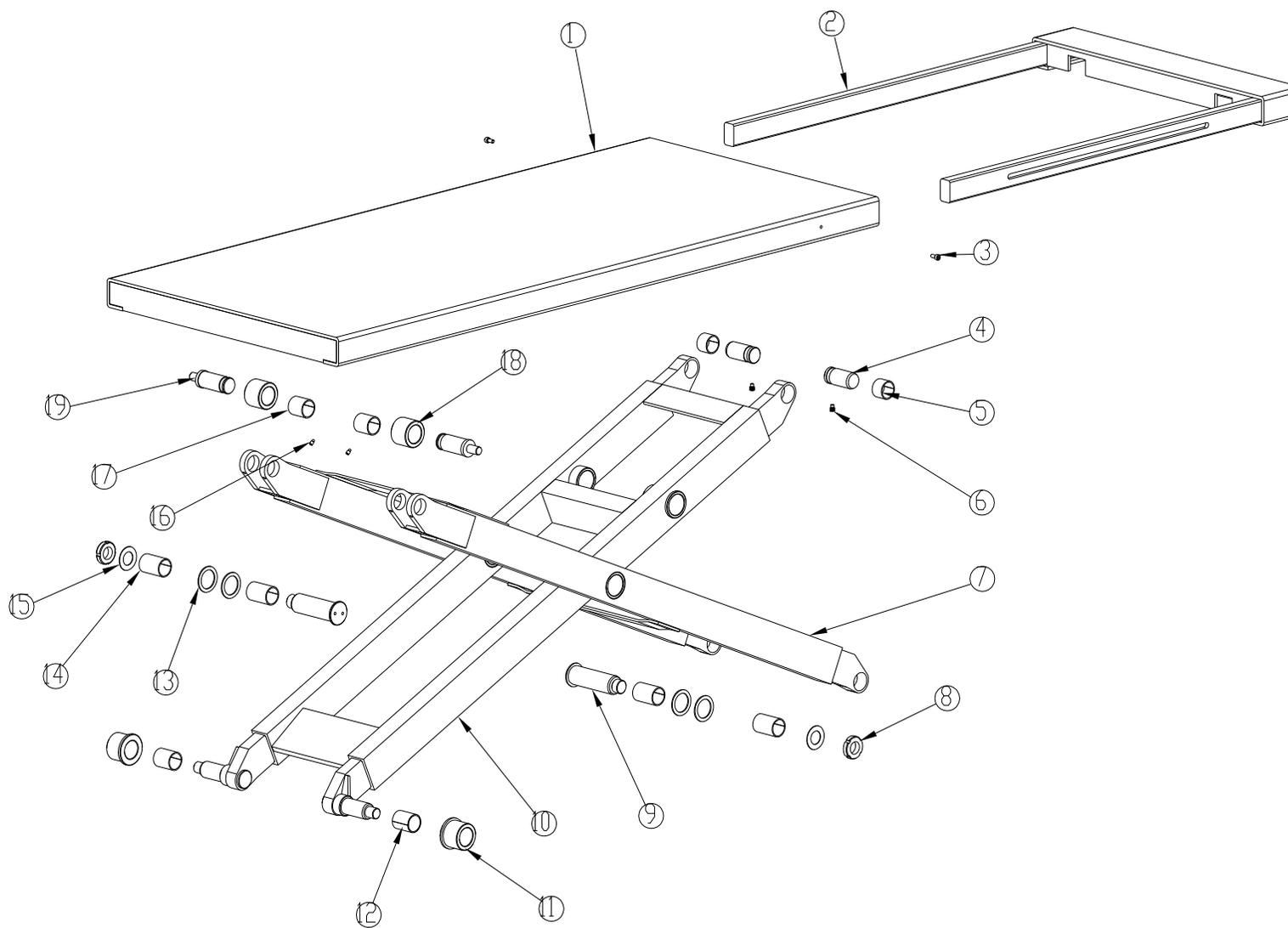

TAV.1.20	WHEEL FREE JACK ASSEMBLY	ED. 04/16
----------	--------------------------	-----------

ITEM	PART NO.	DESCRIPTION	QTY	REMARK
1	824-05-00	Jack table	1	
2	824-05-9	Table extension	1	
3	0202024	Screw M6X12- GB/T70.1	2	
4	8250-04-02-08	Upper shaft	2	
5	0210013	Self-lubricated bush 3024	2	
6	0209025	Screw M8X12 - GB/T79	2	
7	824-152000	Outer scissor arm	1	
8	0204060	Self-locking nut M25X1.5	2	
9	824-04-01-08	Middle shaft	2	
10	824-153000	Inner scissor arm	1	
11	8250-04-02-02	Lower wheel	2	
12	0210016	Self-lubricated bush 3040	2	
13	GJ300-400009	Shim 2	4	
14	0210017	Self-lubricated bush 3050	4	
15	ZJJ3-04-01-09A	Spacer	2	
16	0209002	Screw M6X10 - GB/T79	2	
17	0210057	Self-lubricated bush 3035	2	
18	8250-04-01-02	Upper wheel	2	
19	8250-04-01-01	Upper wheel shaft	2	

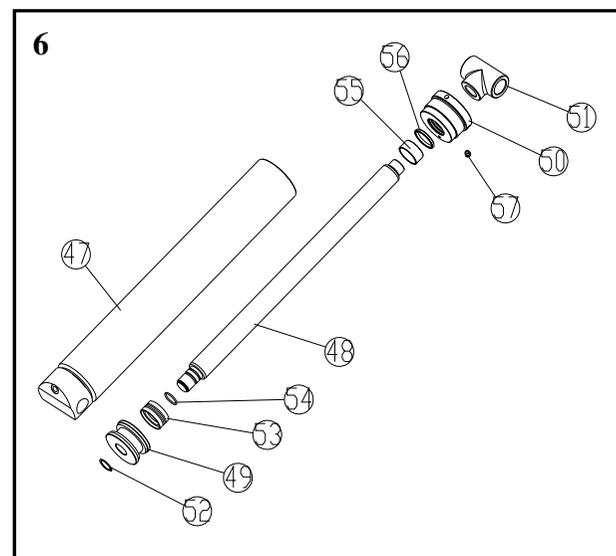
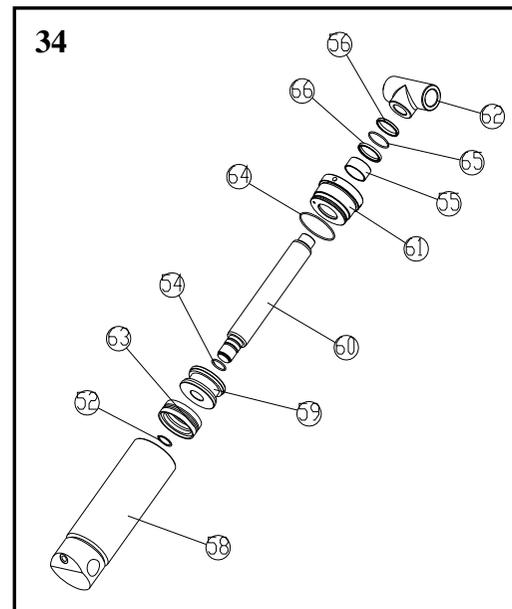
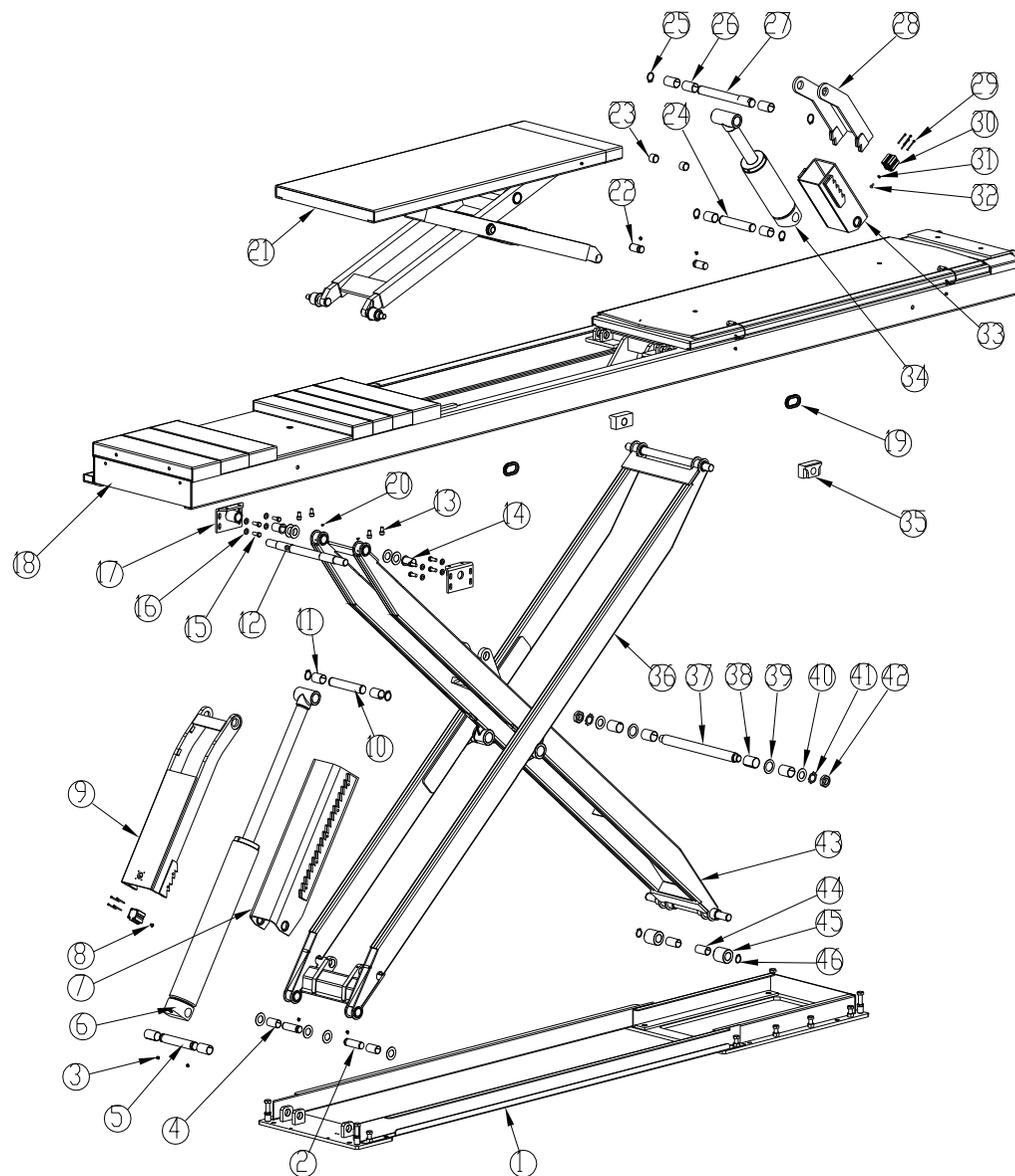

TAV.2.0	RUNWAY P2	ED. 04/16
---------	-----------	-----------

ITEM	PART NO.	DESCRIPTION	QTY	REMARK
1	824-110000G	Base	1	
2	824-100003	Lower shaft	2	
3	0209025	Screw M8X12 - GB/T79	6	
4	0210018	Self-lubricated bush 3055	2	
5	8250-02-01-17	Cylinder lower shaft	1	
6	8250-100-00	Slave hydraulic cylinder	1	
7	8250-06-04	Lower safety rack	1	
8	0207043	Screw M6X10- GB/T973	1	
9	824-161000	Upper safety rack	1	
10	8250-02-01-18	Cylinder upper shaft	1	
11	0210027	Self-lubricated bush 3550	4	
12	824-100005	Upper shaft	1	
13	0202070	Screw M12X20- GB/T70.1	4	
14	0210075	Self-lubricated bush 3050F	2	
15	0201074	Screw M12X30 - GB/T5781	8	
16	0205013	Washer D.12- GB/T97.1	8	
17	824-17000	Arm bracket	2	
18a	825D1-240000	P2 platform assembly	1	For STD-8250D1
18b	825D-240000G	P2 platform assembly	1	For STD-8250D
19	CXQ-61X5.5	Hose holder	2	
20	0209010	Screw M6X10 - GB/T78	2	
21	824-150000G	Wheel free jack assembly	1	
22	8250-04-02-08	Jack lower shaft	2	
23	0210013	Self-lubricated bush 3024	2	
24	8250-06-01	Cylinder lower shaft	1	
25	0212022	Seeger D.35- GB/T894.1	6	
26	0210028	Self-lubricated bush 3560	6	

27	8250-07-01	Cylinder upper shaft	1
28	8250-07-02	Jack upper safety rack	1
29	0202010	Screw M4X50- GB/T70.1	8
30	0306010	Air safety release cylinder 32X23	2
31	0203004	Nut M6 - GB/T52	1
32	0201173	Screw M6X16 - GB/T12	1
33	8250-07-03	Jack lower safety rack	1
34	8250-00C	P2 jack hydraulic cylinder	1
35	824-100001G	Nylon slider	2
36	824-130000G	Outer scissor arm	1
37	824-100004	Middle shaft	1
38	0210080	Self-lubricated bush 4055	4
39	8250-18	Shim	2
40	ZJJ3-7	Shim	10
41	0205025	Teethed washer D.30 - GB/T858	2
42	0204015	Nut M30 - GB/T6172.1	2
43	824-120000G	Inner scissor arm	1
44	0210046	Self-lubricated bush 3060	2
45	8240B-02-02-16	Lower wheel	2
46	0212021	Seeger D.30- GB/T894.2	2
47	8250-100-10	Slave cylinder liner	1
48	8240B-100-04	Cylinder shaft	1
49	GJ350-100B-5	Piston	1
50	GJ350-100B-2	Cylinder guiding cover	1
51	8250-120-06	Shaft support	1
52	0212007	Seeger D.32 - GB/T894.1	2
53	0312003	Gasket 100X75X22.4	1

TAV.2.0	RUNWAY P2	ED. 04/16
---------	-----------	-----------

54	0309027	O-ring 38X3.1	2
55	0305006	Guide ring 50X25X2.5	2
56	0311010	Scraper50X58X5	2
57	0306087	Silencer 1/8	1
58	8250-95-30	P2 jack cylinder liner	1
59	ZJJ40-02B	Piston	1
60	ZJJ40-04C	Cylinder shaft	1
61	ZJJ40-05C	Cylinder guiding cover	1
62	8250-06C	Shaft support	1
63	0312019	Gasket 95X75X22.4	1
64	0309045	O-ring 95X3.1	1
65	0309031	O-ring 55X3.1	1
66	0310015	Seal 50X60X6	1

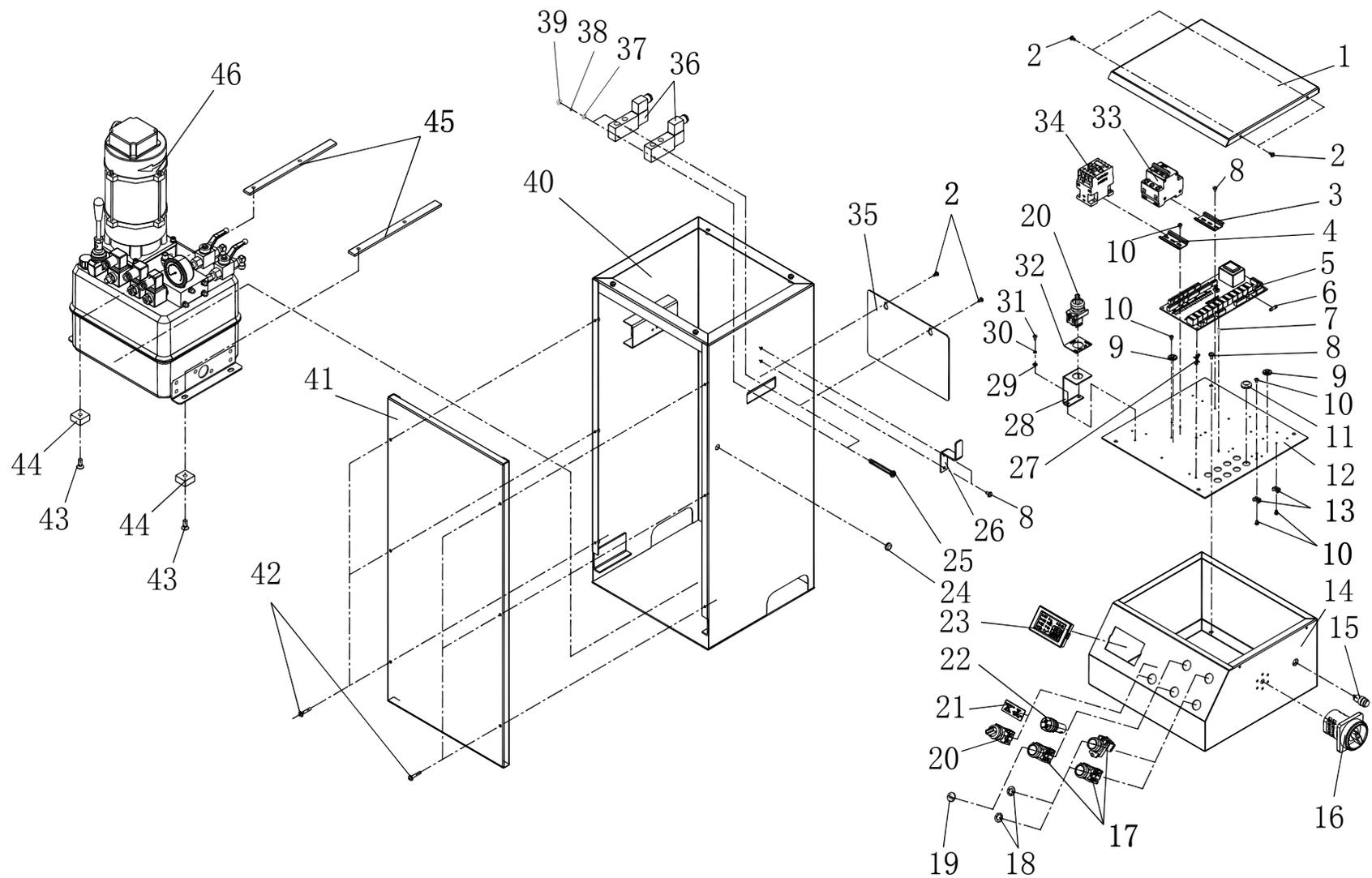

TAV.3.0	CONTROL UNIT	ED. 04/16
---------	--------------	-----------

ITEM	PART NO.	DESCRIPTION	QTY	REMARK
1	J04A030002	Top cover	1	
2	0206059	Screw M4X8	6	
3	0508330	Guide DZ47 L=80mm	1	
4	0508330	Guide DZ47 L=45mm	1	
5	0507349	CPU board 101.2	1	
6	0504016	Fuse 1A(5X20)	3	
7	0204077	Screw M3X12	2	
8	0206058	Screw M5X10	6	
9	0510380	Ground decal	2	
10	0206019	Screw M4X6 - GB/T818	10	
11	0508017	Cable relief GM-2314	8	
12	J04A110001	Support	1	
13	0508018	Holder HC-1(Φ4)	2	
14	J04A113000	Top box	1	
15	0502017	Pushbutton LA16Y-11-Y	1	
16	0505022	Power switch HZ5-2-20A	1	
17	0502024	Pushbutton LAY37T-10	3	
18	0510196	Up decal	2	
19	0510196	Safety lock decal	1	
20	0502004	Selector LAY37T-10X-2	2	
21	0510379	Main/jack selector decal	1	
22	0502021	Beeper AD16-22SM	1	
23	0507163	Function display 502D	1	
24	0508013	Cable relief GM-1710	1	
25	0206071	Screw M3X60 - GB/T818	2	
26	3002002009	Cable holder	1	
27	0508302	Holder HDB-16A	4	

28	3054502200	Support	1	
29	0205002	Washer D.4 - GB/T97.1	2	
30	0208002	Washer D.4 -GB/T93	2	
31	0206023	Screw M4X8 - GB/T818	2	
32	0510182	Decal	1	
33a	0501066	Breaker DZ47-63/3P-D16A	1	For 400V/380V/3Ph
33b	0501074	Breaker DZ47-63/2P-D32A	1	For 230V/220V/1Ph
34	0501001	AC contactor CJX2-1210(220V)	1	
35	3054503904	Back cover	1	
36	0306177	Solenoid air valve G1/4 3V210-08(220V)	2	
37	0205001	Washer D.3 - GB/T97.1	2	
38	0208001	Washer D.3 - GB/T93	2	
39	0203001	Nut M3 - GB52	2	
40	J04A031000	Lower box	1	
41	J04A030003	Front cover	1	
42	0206028	Screw M5X25 - GT/T818	6	
43	0207019	Screw M8X20 - GB/T819.1	4	
44	3032084008	Rubber pad	4	
45	3002005001	Support	2	
46	BZ-W4K1Y	Hydraulic power unit	1	

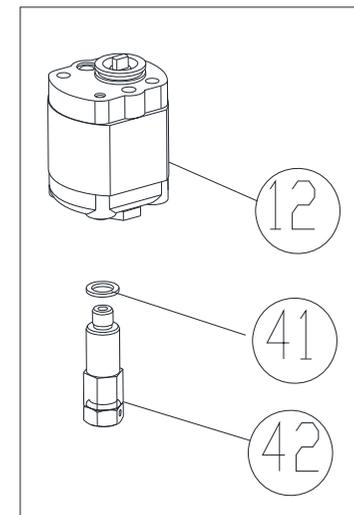
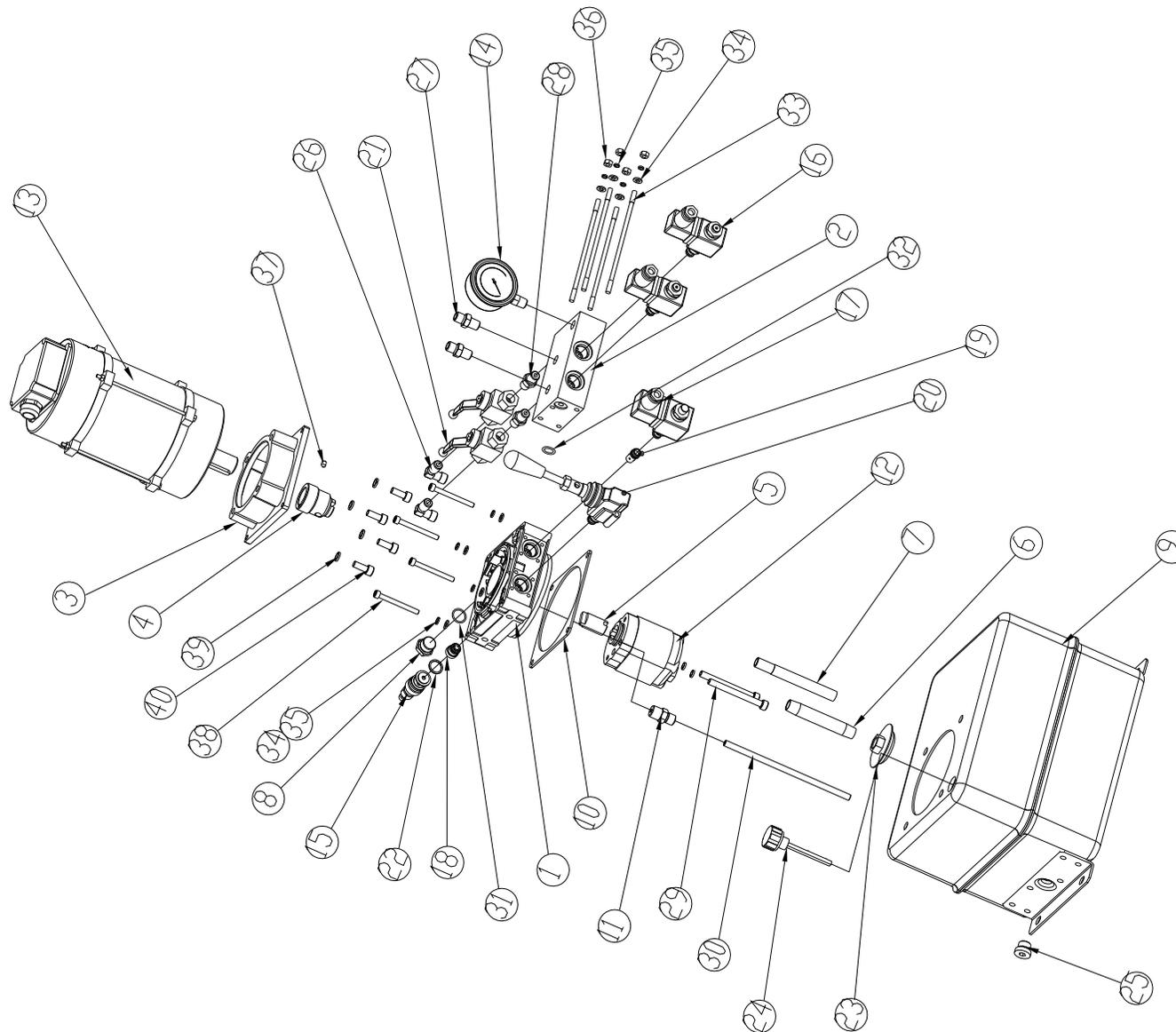

TAV.3.1	HYDRAULIC POWER UNIT	ED. 04/16
---------	----------------------	-----------

ITEM	PART NO.	DESCRIPTION	QTY	REMARK
1	BZ-ZB-W4	Manifold	1	
2	BZ-W-YK1	Interface block	1	
3	BZ-DJ-1B	Motor flange	1	
4	BZ-ZT24	Motor joint	1	
5	BZ-BJ25	Pump joint	1	
6	BZ-G18X110	Oil suction pipe	1	
7	BZ-G14X200	Oil return pipe	1	
8	BZ-SD-01	Manifold plug	1	
9	HK2-0200	Oil tank	1	
10	BZ-F-01	Gasket	1	
11	0306070	Rotation union 3/8	1	
12a	0301022	Gear pump 4.8CC	1	For 3PH motor
12b	0301041	Gear pump 1.6CC	1	For 1PH/50Hz motor
12c	0301040	Gear pump 1.3CC	1	For 1PH/60Hz motor
13a	0509028	Motor 380V/50Hz/3PH 3.5KW	1	
13b	0509071	Motor 220V/50Hz/1PH 2.2kW	1	
13c	0509092	Motor 220V/60Hz/1PH 2.2kW	1	
14	0305054	Pressure gauge 400bar 1/4	1	
15	0307010	Pressure overload valve	1	
16	0307043	Switching solenoid valve 220V	2	
17	0307049	Lowering solenoid valve 220V	1	
18	0307067	Non return valve	1	
19	0307006	Lowering speed control valve D.2.5	1	
20	0301034	Emergency hand pump	1	
21	0307041	Leveling cutoff cock 1/4	2	
22	0303057	Copper washer 16X20	1	
23	0305010	Oil filter 3/8	1	

TAV.3.1	HYDRAULIC POWER UNIT	ED. 04/16
---------	----------------------	-----------

24	0305026	Oil level plug 3/8	1	
25	0305018	Tank plug 3/8	1	
26	0303002	90° union 1/4	2	
27	0303063	Union 1/4	2	
28	0303060	Union 1/4	2	
29	0202052	Screw M8X85 - GB/T70.1	2	
30	0306097	Rilsan hose 8X5 L=190	1	
31	0309054	O-ring 17.0X2.0	1	
32	0309019	O-ring 18X2.4	1	
33	0213032	Screw M6X160 - GB/T901	4	
34	0205006	Washer D.6 - GB/T97.1	8	
35	0208005	Locking washer D.6 - GB/T93	8	
36	0203004	Nut M6 - GB/T6170	4	
37	0209042	Screw M6X8 - GB/T80	1	
38	0202036	Screw M6X65 - GB/T70.1	4	
39	0208006	Locking washer D.8 - GB/T93	6	
40	0202045	Screw M8X20 - GB/T70.1	4	
41	0313001	Washer BS/A13.7	1	
42	BZ-HC2-0	Starting valve for 1Ph	1	Optional

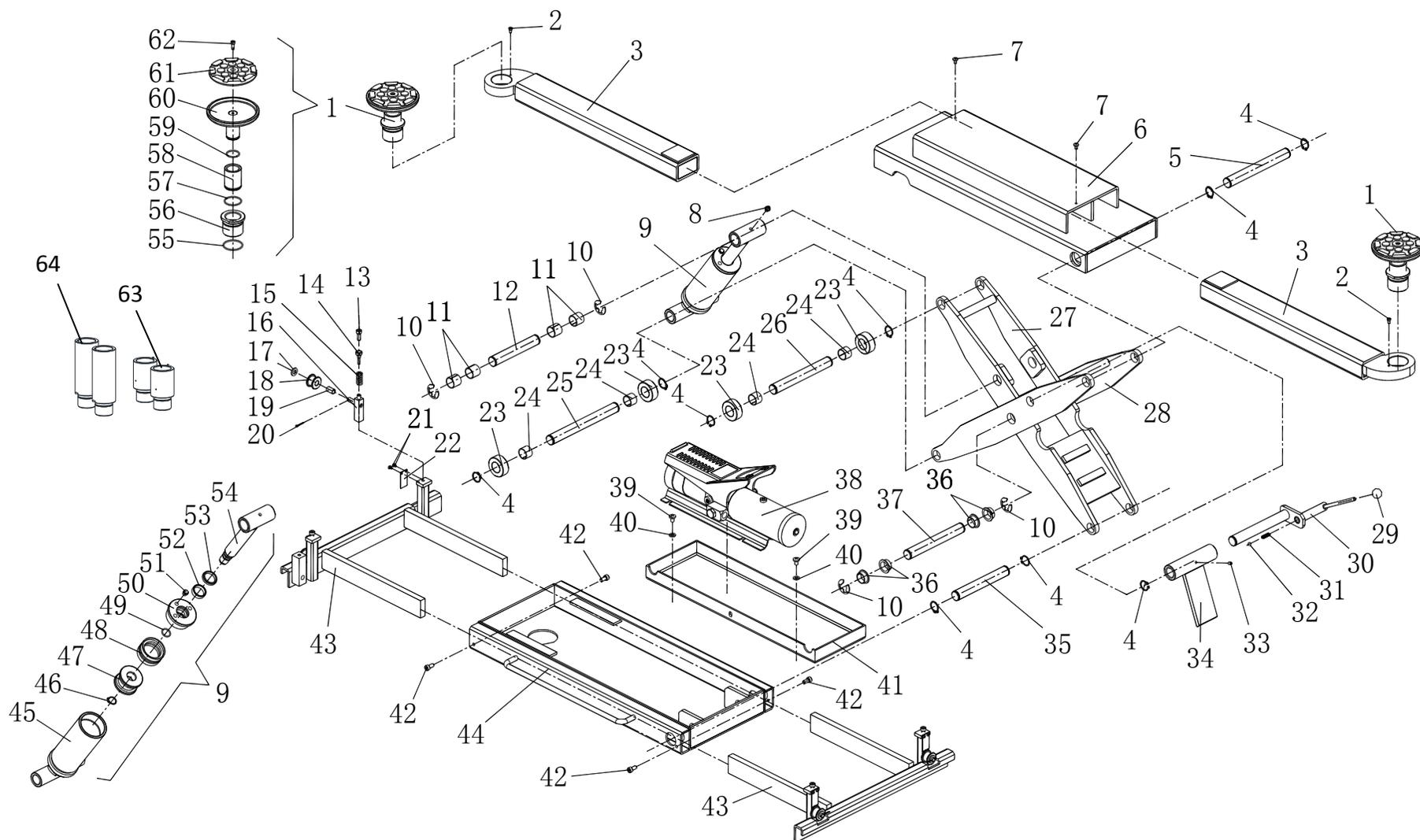

TAV.24.0	JACKING BEAM	ED. 04/16
----------	--------------	-----------

ITEM	PART NO.	DESCRIPTION	QTY	REMARK
1	Z23A313000	Lifting adaptor assembly	2	
2	0202020	Screw M5X8 - GB/T70.1	2	
3	J07K220000	Lifting arm	2	
4	0212004	Seeger D.25	9	
5	HJ-RG-10-4	Shaft	1	
6	J07K210000	Beam	1	
7	0206031	Screw M6X10 - GB/T818	2	
8	0215021	Greaser 8X1	1	
9	HJ-63-0	Jack hydraulic cylinder unit	1	
10	0211003	Seeger D.19	4	
11	0210009	Bush SF-1/2525	4	
12	HJ-RG-19	Cylinder upper shaft	1	
13	0202045	Screw 8X20 - GB/T70.1	4	
14	J07K180001	Pin	4	
15	HJ-RG-18	Spring	4	
16	J07K130000	Slider	4	
17	0205011	Washer D.10 - GB/T97.1	4	
18	HJ-RG-14	Roller	4	
19	0210001	Bush SF-1/1020	4	
20	0213044	Split pin 2X20	4	
21	0206019	Screw M4X6 - GB/T818	8	
22	J07K180002	Anti-derailment plate	4	
23	HJ-RG-11-1	Wheel	4	
24	0210008	Bush SF-1/2520	4	
25	HJ-RG-10-5	Cylinder lower shaft	1	
26	HJ-RG-10-3	Shaft	1	
27	J07K400000	Inner scissor arm	1	

28	J07K300000	Outer scissor arm	1
29	0215016	Handle knob M8X25	1
30	HJ-RG-08-0	Safety release handle	1
31	HJ-SB-19-3	Spring	1
32	0215038	Steel ball D.8	1
33	0209010	Screw M6X10 - GB/T78	1
34	HJ-RG-09-0	Safety hook	1
35	HJ-RG-10-1	Shaft	1
36	0210066	Bush SF-1/2512F	4
37	HJ-RG-10-2	Central shaft	1
38	0301030	Air-hydraulic pedal pump 650CC	1
39	0206001	Screw M8X12 - GB/T818	2
40	0205008	Washer D.8 - GB/T97.1	2
41	6740A-61101A	Pump tray	1
42	0202040	Screw M8X16 - GB/T70.1	4
43	J07K120000	Base extension	2
44	J07Q110000	Jack base	1
45	HJ-63-1	Jack cylinder liner	1
46	0212005	Seeger D.20	1
47	8240TX-63-2	Jack cylinder piston	1
48	0312012	Gasket 63X47X18.4	1
49	0309022	O-ring 24X2.4	1
50	8240TX-63-3	Cylinder guiding cover	1
51	0306087	Silencer 1/8	1
52	0305007	Guiding ring 30x10x2.5	1
53	0311005	Scraper 30X38X5/6.5	1
54	HJ-75-4	Cylinder shaft	1

TAV.24.0	JACKING BEAM	ED. 04/16
----------	--------------	-----------

55	0309091	O-ring 45X2.65	2	
56	Z23A313002	Outer threaded bush	2	
57	0212034	Seeger D.42	2	
58	Z23A313001	Inner threaded bush	2	
59	0212035	Seeger D.32	2	
60	Z23A313100	Pad support	2	
61	Z23A313202	Rubber pad	2	
62	0202032	Screw M6X16 - GB/T70.1	2	
63	Z23A601200	Adaptor extension H80	2	For special request
64	Z23A601300	Adaptor extension H155	2	For special request

HYDRAULIC LINE

ED. 04/16

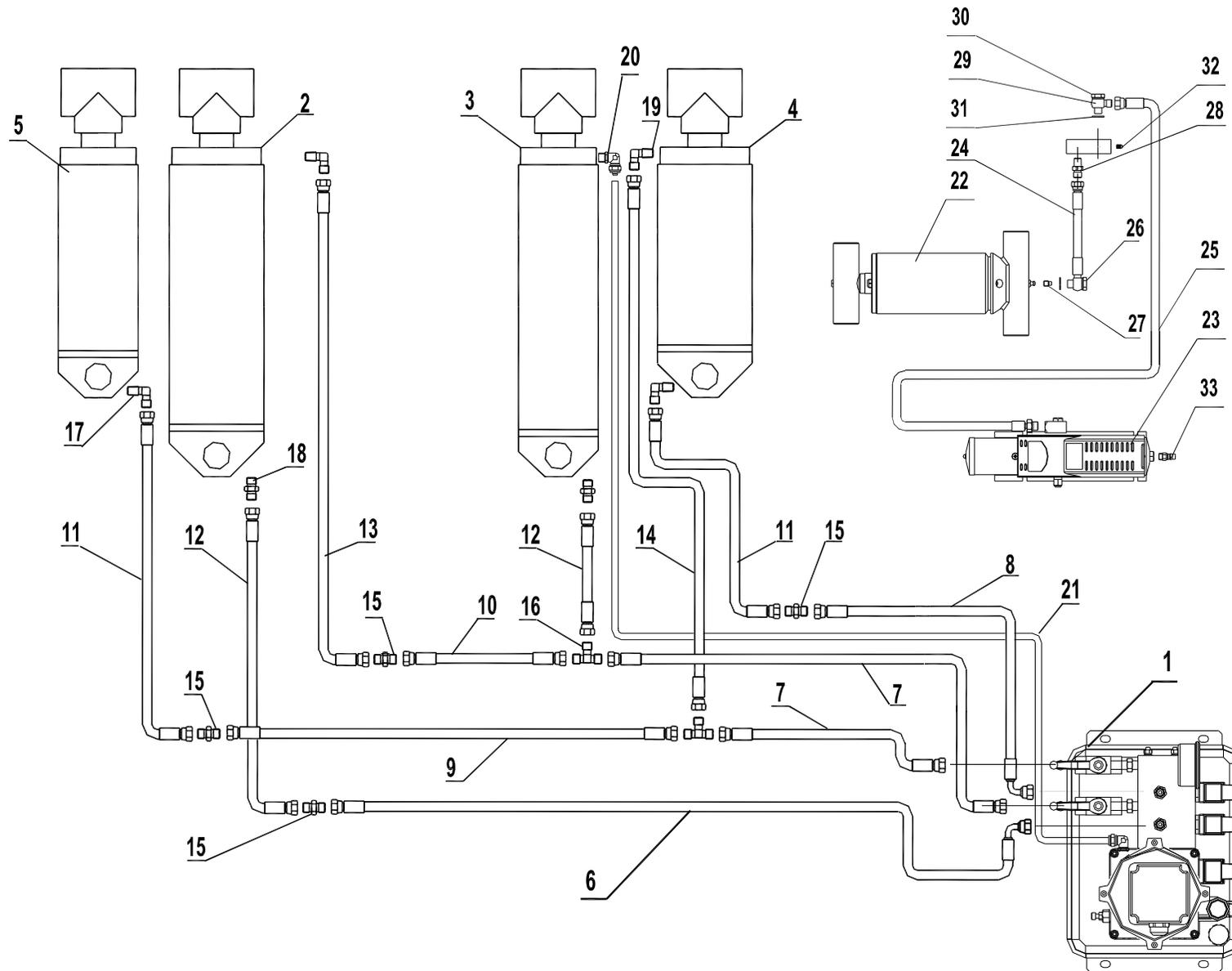

HYDRAULIC LINE

ED. 04/16

ITEM	PART NO.	DESCRIPTION	QTY	REMARK
1	BZ-W4K1Y	Hydraulic power unit	1	
2	8250-120-00	Master hydraulic cylinder	1	
3	8250-100-00	Slave hydraulic cylinder	1	
4	8250-00C	Jack master hydraulic cylinder	1	
5	8250-00D	Jack slave hydraulic cylinder	1	
6	ZW5430	Hydraulic hose 1/4 L=5430	1	
7	ZZ3600	Hydraulic hose 1/4 L=3600	2	
8	ZW3700	Hydraulic hose 1/4 L=3700	1	
9	ZZ1800	Hydraulic hose 1/4 L=1800	1	
10	ZZ1400	Hydraulic hose 1/4 L=1400	1	
11	ZZ5350	Hydraulic hose 1/4 L=5350	2	
12	ZZ370	Hydraulic hose 1/4 L=370	2	
13	ZZ1200	Hydraulic hose 1/4 L=1200	1	
14	ZZ5700	Hydraulic hose 1/4 L=5700	1	
15	0303065	Union (1B-04)	4	
16	0303021	Tee union (AB-04)	2	
17	0303002	90 degree union (1BT9-04SP)	2	
18	0303063	Union (1BT-04SP)	2	
19	0303003	90 degree union (1BT9-04SP-Y)	2	
20	0303067	Union (Φ 10 ZG1/4)	1	
21	0306109	PU hose (Φ 10XΦ 6.5X4900C)	1	
22	HJ-63-0	Jack hydraulic cylinder	1	
23	0301030	Air pedal pump TK608	1	
24	ZJ380	PU hydraulic hose L=380	1	
25	ZY1090	Hydraulic hose L=1090	1	
26	BZ-720B-0401	Bolt	1	
27	BZ-GZ-002	Screw	1	

	HYDRAULIC LINE		ED. 04/16
--	----------------	--	-----------

28	0303063	Union (1BT-04SP)	1
29	0303030	Union (1BI-04B)	1
30	0303027	Bolt (720B-04)	1
31	0313001	Washer (BS/A13.70)	1
32	0305001	Plug (ZBJ22 007-QD07)	1
33	0306112	Quick union (Φ8 G1-4)	1

PNEUMATIC LINE

ED. 04/16

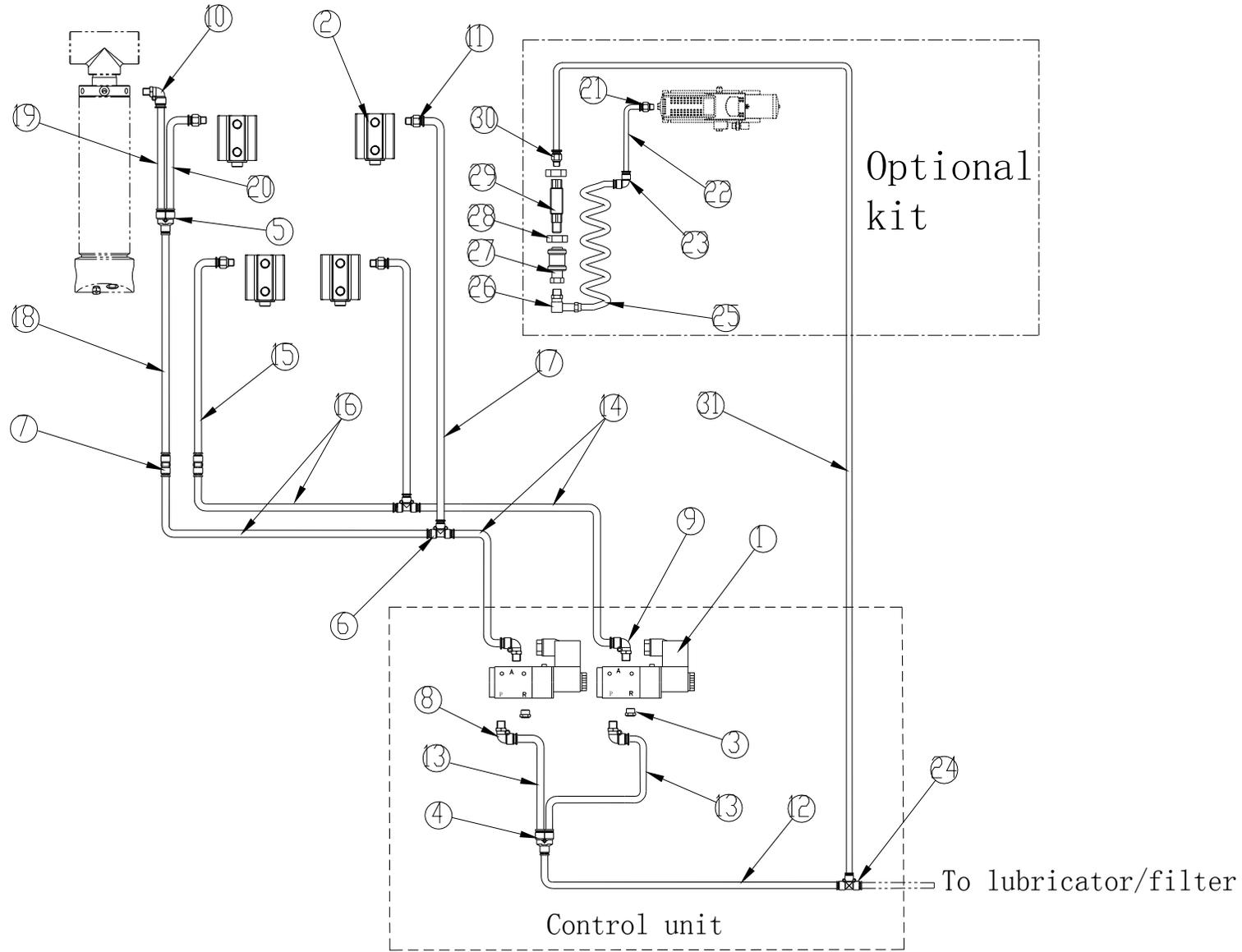

PNEUMATIC LINE

ED. 04/16

ITEM	PART NO.	DESCRIPTION	QTY	REMARK
1	0306190	Solenoid air valve DC24V	2	
2	0306010	Air safety release cylinder 32X23	4	
3	0306086	Silencer 1/4	2	
4	0306002	Y quick union 8	1	
5	0306158	Y quick union 6	1	
6	0306025	Tee quick union 6	2	
7	0306041	Quick union 6	2	
8	0306032	90 degree quick union 8-1/4	2	
9	0306047	90 degree quick union 6-1/4	2	
10	0306040	90 degree quick union 6-1/8	1	
11	0306046	Quick union 6-1/8	4	
12	0306097	Rilsan hose 8X5 L=1000	1	
13	0306097	Rilsan hose 8X5 L=120	2	
14	0306095	Rilsan hose 6X4 L=4200	2	
15	0306095	Rilsan hose 6X4 L=2600	2	
16	0306095	Rilsan hose 6X4 L=2200	2	
17	0306095	Rilsan hose 6X4 L=5500	1	
18	0306095	Rilsan hose 6X4 L=5200	1	
19	0306095	Rilsan hose 6X4 L=600	1	
20	0306095	Rilsan hose 6X4 L=300	1	
21	0306043	Quick union 6-1/4	1	Optional
22	0306095	Rilsan hose 6X4 L=850	1	Optional
23	0306121	90 degree quick union 6	1	Optional
24	0306022	Tee quick union 8	1	Optional
25	0306101	Spiral rilsan hose 6X4 L=4000	1	Optional
26	0306082	Rotation 90 degree union 6-1/4	1	Optional
27	0306192	Switching valve VMS-114	1	Optional

	PNEUMATIC LINE			ED. 04/16
--	----------------	--	--	-----------

28	8250N61-810002G	Special nut	2	Optional
29	8250N61-810001G	Union	1	Optional
30	0306044	Quick union 8-1/4	1	Optional
31	0306097	Rilsan hose8X5 L=12000	1	Optional